

GWM WORM GEARED MOTOR

Ratio Up to 10000/1

Max. Output Torque : 2500Nm

About Us:

Gaeyah Transmission an Indian company, manufacturing efficient power transmission products to meet the growing aspirations of Indian customers. Gaeyah is mentored by qualified, experienced engineers having expertise in various applications, solutions and wide industry segments. We promise to deliver right combination of efficient, affordable and quality products for the light duty industry segment.

Our Vision:

“Gaeyah’s vision to offer affordable power transmission solutions, thereby empowering Indian customers to improve their product performance”

Our Values:

Inclusiveness: Respect all living being

Honesty: Upright and fair

Commitment: Promise to persevere

Innovate: Contemporary Solutions

Passion: Empathize and Listen

Our Worm Gear Reducers



● **GWM 025-150**



● **GWM-GW 025-150**



● **GWM 025-150 F**



● **GW 025-150 SISO**



● **GW 025-150 F**



● **GW 025-150 SIHO**

NOTE: SISO - Solid In Solid Out, SIHO - Solid In Hollow Out

CONTENTS

- 2 ▶ BACK DRIVE TABLE
- ▶ APPLICATIONS
- 3 ▶ USE & SAFETY GUIDELINES
- ▶ PRODUCT CHARACTERISTICS
- 4 ▶ VERSIONS
- 5 ▶ INPUT DIMENSIONS
- 6 ▶ GWM/GW ORDERING GUIDE
- 7 ▶ MOUNTING POSITIONS
- 8 ▶ OVERHUNG LOAD CAPACITY
- 10 ▶ GWM/GW RATING CHART
- 14 ▶ IEC SHAFT DIMENSIONS
- 15 ▶ GWM DIMENSIONS
- 25 ▶ GW DIMENSIONS
- 27 ▶ GWM+GW ORDERING GUIDE
- 28 ▶ MOUNTING POSITIONS
- 29 ▶ GMRV+GMRV RATING CHART
- 33 ▶ GWM+GW DIMENSIONS
- 37 ▶ LUBRICANT
- 38 ▶ GENERAL COMPLAINTS & SOLUTIONS
- 39 ▶ SERVICE FACTOR
- ▶ INSTALLATION NOTES

Back Drive Table:

		Reversibility									
Static reversing	Dynamic reversing	Model	30	40	50	63	75	90	110	130	150
Yes	Yes	Ratio	—	7	7	7	7	7	7	7	7
Yes	Yes		7	10	10	10	10	10	10	10	10
			10	14	14	12	15	15	15	15	15
Uncertain	Yes		15	20	18	19	20	30	30	30	30
			20	28	24	24	25	40	40	40	40
			30	35	28	30	30	46	46	46	46
No	Low		40	46	45	45	50	64	64	80	80
			60	60	60	60	60	80	80	80	100
			70	70	70	80	80	100	100	—	—
No	No		70	100	80	100	100	—	—	—	—
				100							

Applications:

- Material Handling Equipments
- Pollution Equipments
- Printing and Dyeing Industry
- Chemical & Pharmaceutical Industry
- Storage & Logistic System
- Food and Beverage System
- Mechanical Garage
- Road Making Machines
- Packaging Machines
- Textile Machines
- Stage Equipments
- Construction Machines
- Lift and Transportation Machines, etc.



Use and Safety Guidelines:

1. Please check and confirm the matching torque between worm gear reducer and the mechanical equipment before use to ensure that it is in the safety range of worm gear reducer performance parameters.
2. Worm gear reducer has filled with lubricating oil. Please replace the lubricating oil after the first starting of 400 hours and after then 4000 hours for lubricating oil replacing cycle.
3. There should be enough lubrication in worm gear box and keep regular check with the oil level.
4. While installing the gear unit, please be careful to avoid sharp instruments bruising the oil seals on input/ output shaft to cause leakage.
5. Please confirm the direction of rotation the before mechanical connection. If the direction of rotation is not correct, it will possibly injure or damage the devices.
6. Please set safety covers over rotating parts to avoid injury.
7. Please pay full attention: Handle with care to avoid a fall while moving from one location to another.

Products Characteristics:

1. **Compact:** Mounting of motor on the gear unit alongside the equipment possible with GWM units. Hollow output shaft reduces gap between equipment and gear unit.
2. **Self-Locking:** For applications requiring minor holding force, save the cost of braking device, such as inclined conveyor.
3. **Fast Stop:** The ordinary gear reducers available in the market requires 5-10 seconds to stop. While GWM series product need only 2-5 seconds to stop.
4. **High Accommodation:** Plug in output shaft. Single output shaft extension or dual output shaft extension, easy to modify, only one minute to complete the shaft disassemble and assemble.
5. **High Safety:** Use transmission different from conventional method, no sprocket pulley is needed, no exposed transmission structure, Reduce the possibility of operator.
6. **Good Protection:** IP55 class protection against water, dust and moisture.
7. **Allows Multiple Sides Installation:** No restriction in angle: There are holes for mounting on all plain surface of the product series allows customer to select required direction and angle.
8. **Excellent Cooling Effect:** Pressure die-cast aluminum alloy casing, designed with many fins helps quick heat dissipation leading to extended life for worm, worm gear, bearings and seals.
9. **Easy Maintenance:** Different from conventional mounting method, no need to disassemble the sprocket or pulley, only disassemble and Assemble the mounting base of the reducer to complete the modification easily.
10. **Wide reduction ratio:** Reduction ratio available from 7.5 to 10000/1. The units are designed modular to assemble and disassemble.

Versions

	GWM 025-150	GWM 025-150 F	
	GW 025-150	GW 025-150 F	
	GWM-GW 025-150	GWM-GW 025-150 F	
	GW-GW 025-150	GW-GW 025-150 F	

Input Dimensions

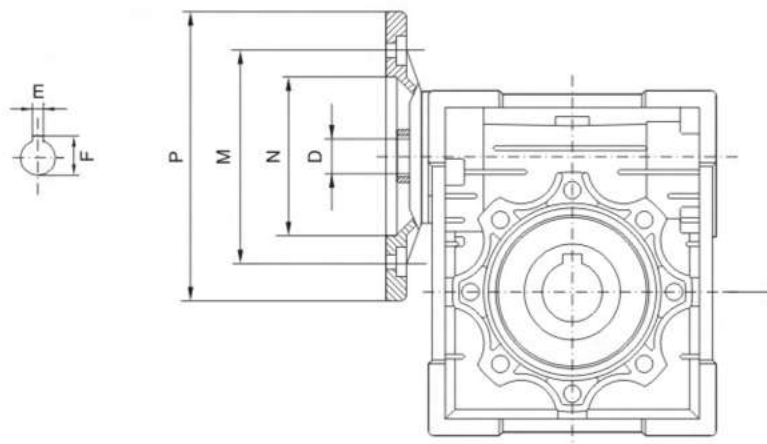

MODEL	Motor Flange						D The Hole Diameter of Shaft											
	PAM IEC	N	M	P	E	F	i Transmission Ratio											
							7.5	10	15	20	25	30	40	50	60	80	100	
GWM025	56B14	50	65	80	3	10.4	9	9	9	9	-	9	9	9	9	-	-	
	63B5	95	115	140	4	12.8	11	11	11	11	11	11	11	11	-	-	-	
GWM030	63B14	60	75	90	3	10.4	9	9	9	9	9	9	9	9	9	9	-	
	56B5	80	100	120			9	9	9	9	9	9	9	9	9	9	9	-
GWM040	71B5	110	130	160	5	16.3	14	14	14	14	14	14	14	-	-	-	-	
	71B14	70	85	105			14	14	14	14	14	14	14	14	-	-	-	-
	63B5	95	115	140	4	12.8	11	11	11	11	11	11	11	11	11	11	11	
	63B14	60	75	90			11	11	11	11	11	11	11	11	11	11	11	11
GWM050	56B5	80	100	120	3	10.4	-	-	-	-	-	-	-	9	9	9	9	
	80B5	130	165	200	6	21.8	19	19	19	19	19	19	-	-	-	-	-	
	80B14	80	100	120			19	19	19	19	19	19	19	19	19	19	19	-
	71B5	110	130	160	5	16.3	14	14	14	14	14	14	14	14	14	14	14	-
71B14	70	85	105	14			14	14	14	14	14	14	14	14	14	14	14	
GWM063	63B5	95	115	140	4	12.8	-	-	-	-	-	-	11	11	11	11	11	
	90B5	130	165	200	8	27.3	24	24	24	24	24	24	-	-	-	-	-	
	90B14	95	115	140			24	24	24	24	24	24	24	24	24	24	24	24
	80B5	130	165	200	6	21.8	19	19	19	19	19	19	19	19	19	19	19	-
	80B14	80	100	120			19	19	19	19	19	19	19	19	19	19	19	19
71B5	110	130	160	5	16.3	-	-	-	-	-	-	14	14	14	14	14	14	
71B14	70	85	105			14	14	14	14	14	14	14	14	14	14	14	14	
GWM075	100/112B5	180	215	250	8	31.3	28	28	28	-	-	-	-	-	-	-	-	
	100/112B14	110	130	160			28	28	28	28	28	28	28	28	28	28	28	28
	90B5	130	165	200	8	27.3	24	24	24	24	24	24	24	24	24	24	24	
	90B14	95	115	140			24	24	24	24	24	24	24	24	24	24	24	24
	80B5	130	165	200	6	21.8	-	-	-	19	19	19	19	19	19	19	19	19
80B14	80	100	120	19			19	19	19	19	19	19	19	19	19	19	19	
GWM090	100/112B5	180	215	250	8	31.3	28	28	28	28	28	28	-	-	-	-	-	
	100/112B14	110	130	160			28	28	28	28	28	28	28	28	28	28	28	28
	90B5	130	165	200	8	27.3	24	24	24	24	24	24	24	24	24	24	24	
	90B14	95	115	140			24	24	24	24	24	24	24	24	24	24	24	24
	80B5	130	165	200	6	21.8	-	-	-	-	-	-	19	19	19	19	19	
80B14	80	100	120	19			19	19	19	19	19	19	19	19	19	19		
GWM110	132B5	230	265	300	10	41.1	38	38	38	38	-	-	-	-	-	-	-	
	100/112B5	180	215	250	8	31.3	28	28	28	28	28	28	28	28	28	28	28	
	90B5	130	165	200	8	27.3	-	-	-	-	24	24	24	24	24	24	24	
GWM130	132B5	230	265	300	10	41.1	38	38	38	38	38	38	38	-	-	-	-	
	100/112B5	180	215	250	8	31.3	-	-	-	-	28	28	28	28	28	28	28	
GWM150	160B5	250	300	350	12	45.3	42	42	42	42	42	-	-	-	-	-	-	
	132B5	230	265	300	10	41.3	-	-	-	38	38	38	38	38	38	38	38	
	100/112B5	180	215	250	8	31.3	-	-	-	-	-	-	-	-	28	28	28	

All Dimensions are in mm

GWM/ GW, How to Order?

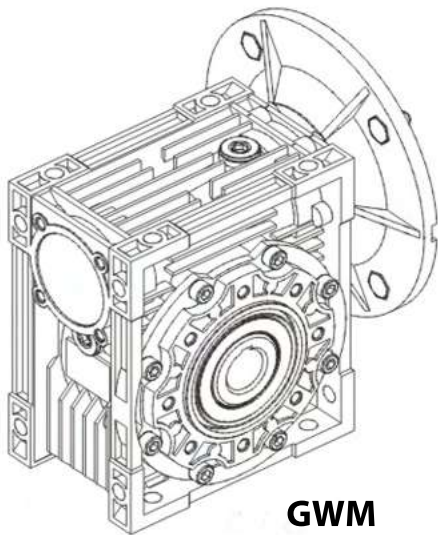

GWM

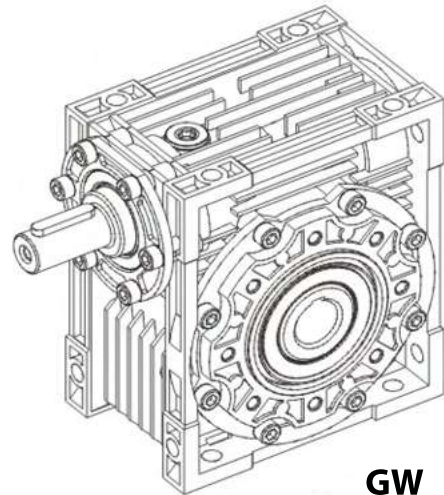

GW

Type	Ratio	Double Input Shaft	Output	Input Flange	Mounting Position
------	-------	--------------------	--------	--------------	-------------------

GWM 063 – 30 – VS – FA1-ASR-A1 – 80B5 – B3

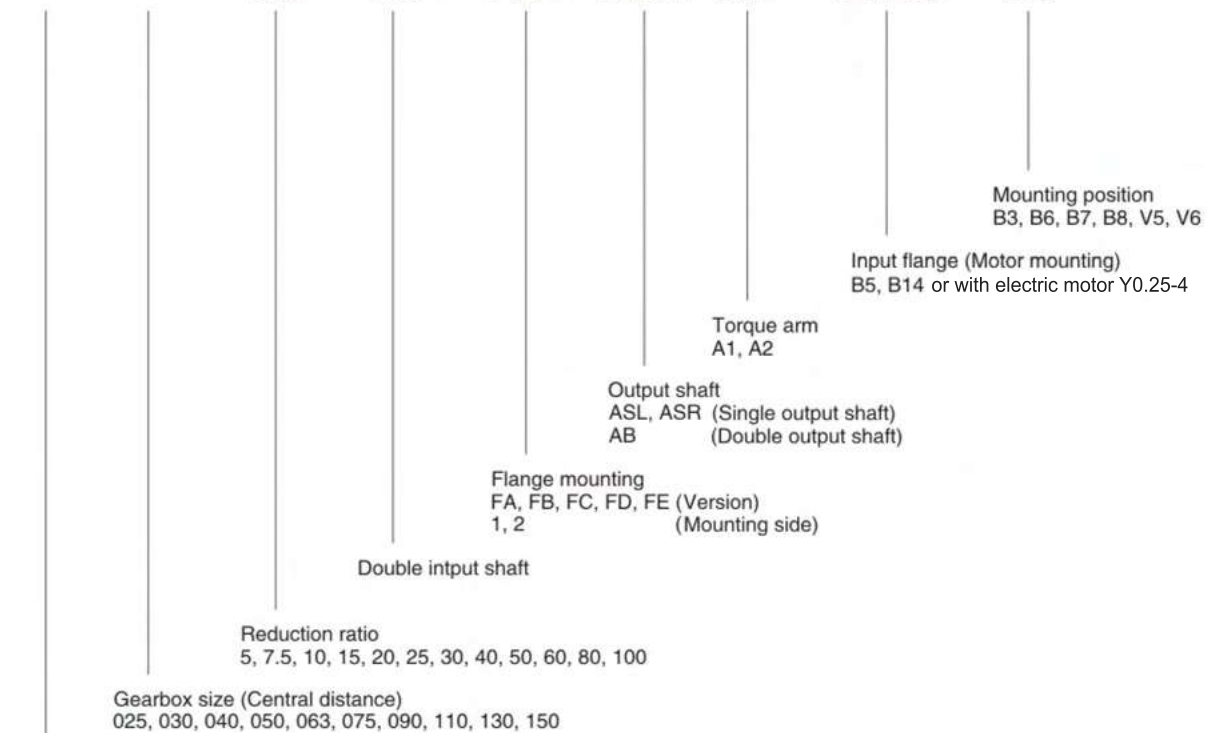

Worm gearbox type
 GMRV=Worm-gear unit with IEC motor interface
 GRV=Worm speed reducer with solid input shaft

Mounting Positions

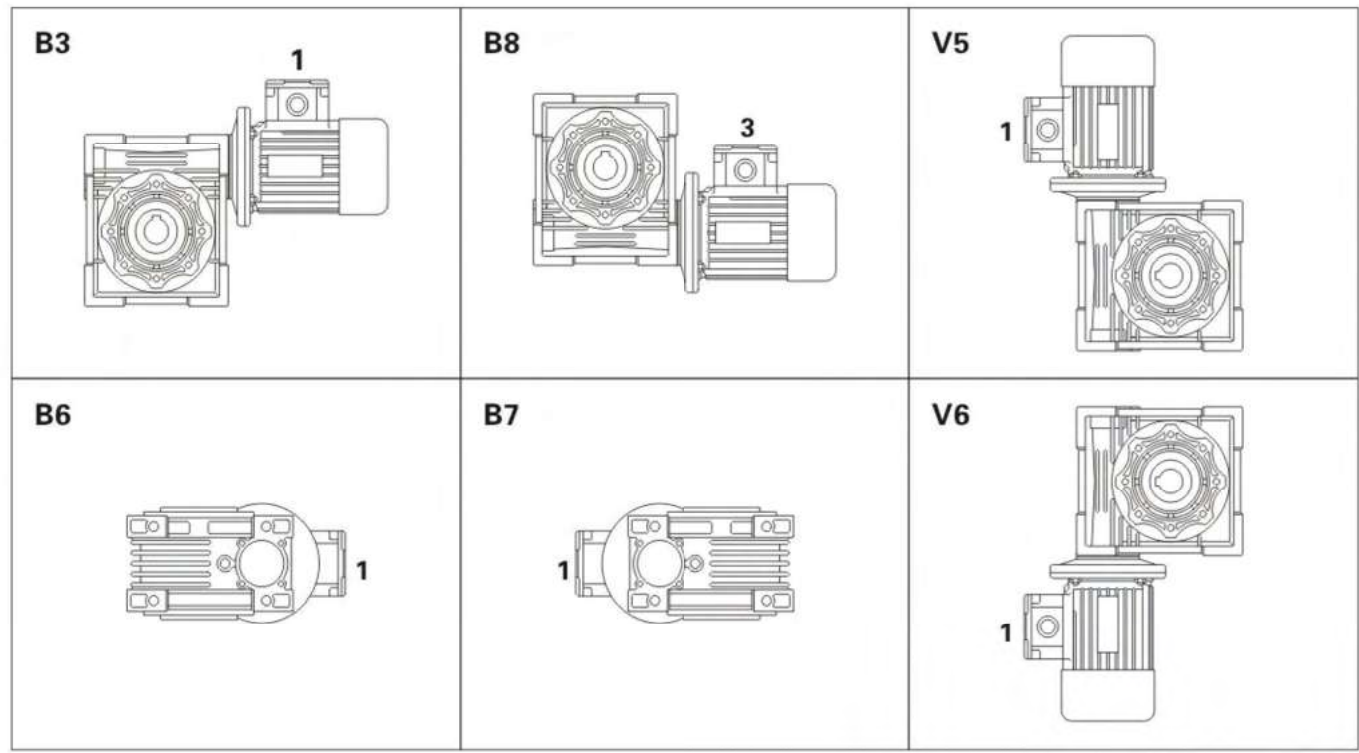

Flange F-FL

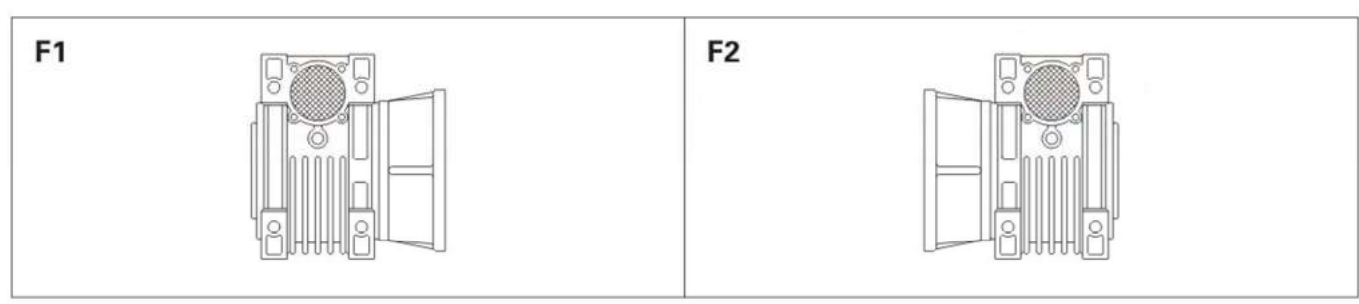

Position of Terminal Box

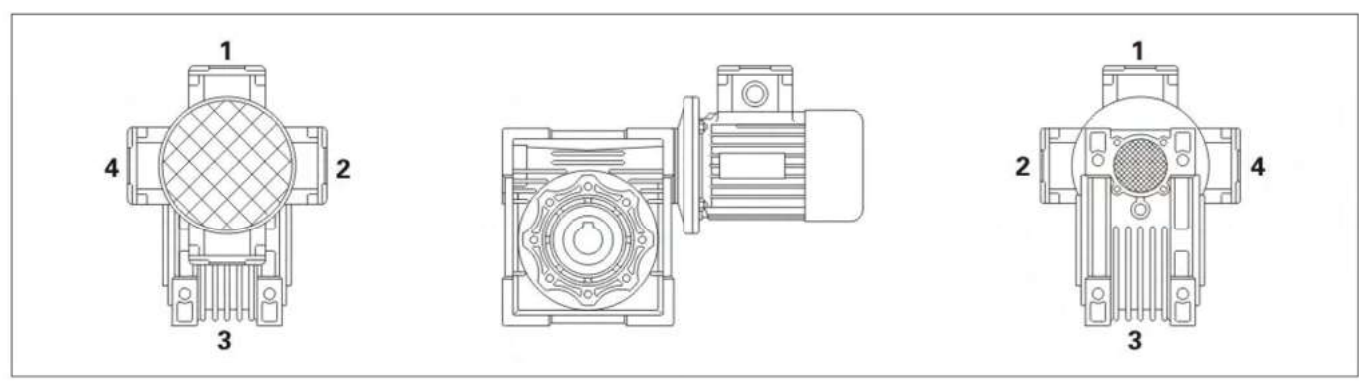

MOUNTING & BREATHER PLUG POSITION

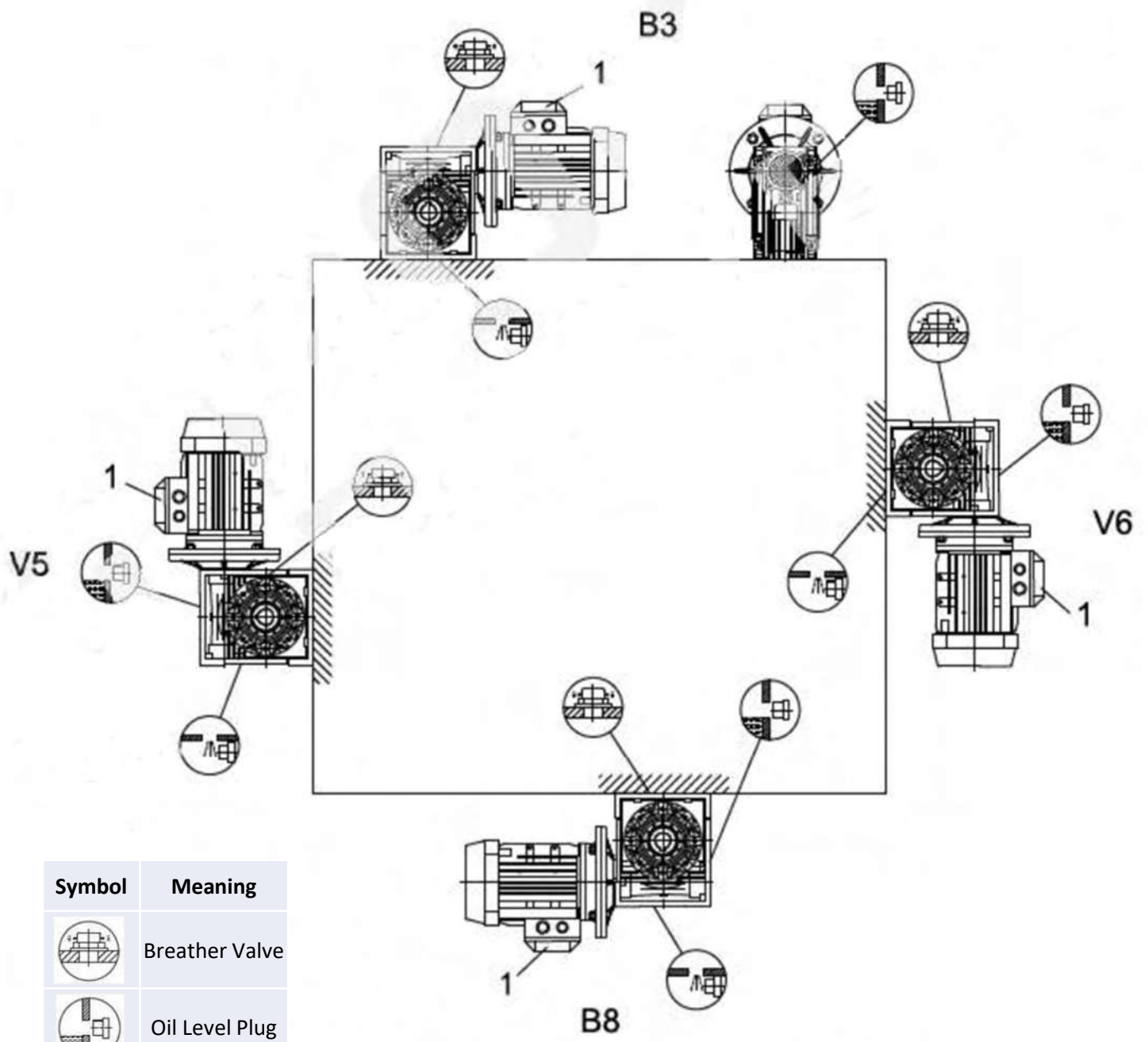

Symbol	Meaning
	Breather Valve
	Oil Level Plug
	Oil Drain Plug

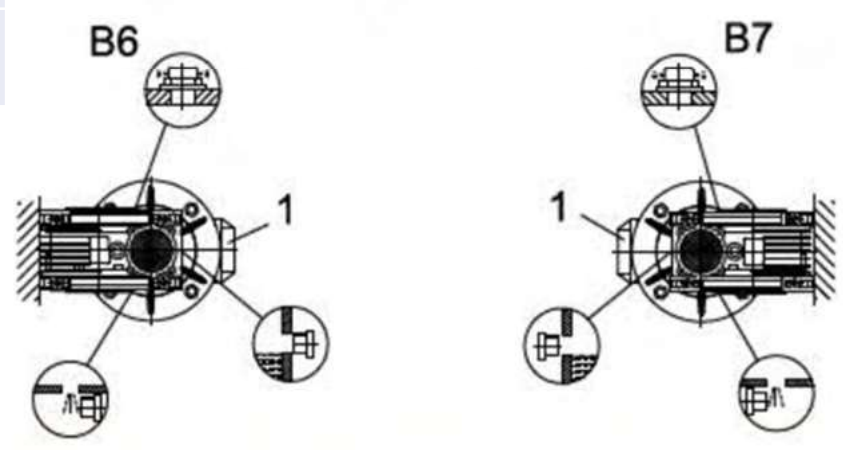

Applied mid-way along the Input Shaft

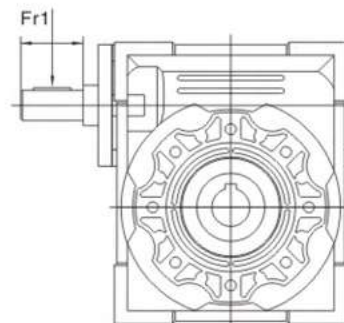

(N)

n1	GWM030	GWM040	GWM050	GWM063	GWM075	GWM090	GWM110	GWM130	GWM150
1440	150	250	350	500	700	900	1200	1500	1950
960	175	290	400	580	810	1040	1390	1740	2262
500	210	350	490	700	980	1270	1700	2100	2730

Applied mid-way along the Output Shaft

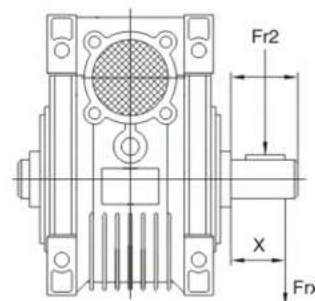

$$F_{rx} = Fr \frac{a}{b+x}$$

(N)

n2	GWM025	GWM030	GWM040	GWM050	GWM063	GWM075	GWM090	GWM110	GWM130	GWM150
400	390	530	1020	1400	1830	2160	2390	3020	3950	5532
250	460	620	1200	1650	2150	2520	2800	3530	4610	6456
150	550	740	1420	1960	2540	2990	3310	4180	5470	7660
100	630	850	1620	2250	2910	3430	3800	4790	6260	8767
60	740	1000	1920	2660	3450	4060	4500	5680	7420	10391
40	850	1150	2200	3050	3950	4650	5150	6500	8500	11903
25	990	1350	2570	3570	4620	5440	6020	7600	9940	13920
10	1350	1830	3490	4840	6270	7380	8180	10320	13500	16500
a	50	65	84	101	120	131	162	191	203	218
b	38	50	64	76	95	101	122	151	163	176

- Above table is the allowed loading force on the midpoint of output shaft.
- When the reducer is with double output shafts, the resultant radial power at the edge of shaft should not exceed the values specified as in above table.
- The max allowed axial thrust is 1/5 of radial force while the radial force and axial force effected together.

GWM / GW Rating Chart

Single Stage Reducer (Input speed 1440r/min)

Model	N ₂ (r/min)	M ₂ (N.m)	i	kN	f.s.	
0.06kw						
GWM025	186.7	2.6	7.5	0.50	4.2	
	140	3.4	10	0.55	3.5	
	93.3	4.9	15	0.63	2.5	
	70	6.1	20	0.69	2.0	
	46.7	8.2	30	0.79	1.6	
	35	10	40	0.87	1.3	
	28	12	50	0.94	0.9	
	23.3	14	60	1.00	0.7	
GWM030	186.7	2.6	7.5	0.68	6.9	
	140	3.4	10	0.75	5.4	
	93.3	4.7	15	0.86	3.8	
	70	6	20	0.94	3.0	
	56	7	25	1.02	3.0	
	46.7	8	30	1.08	2.5	
	35	9.7	40	1.19	1.9	
	28	11	50	1.28	1.5	
GWM025	23.3	13	60	1.36	1.3	
	17.5	14	80	1.50	0.9	
	0.09kw					
	GWM025	186.7	3.9	7.5	0.50	2.8
		140	5.1	10	0.55	2.4
		93.3	7.3	15	0.63	1.6
		70	9.2	20	0.69	1.3
		46.7	12	30	0.79	1.1
35		15	40	0.87	0.9	
GWM030	186.7	3.9	7.5	0.68	4.6	
	140	5	10	0.75	3.6	
	93.3	7.1	15	0.86	2.5	
	70	9	20	0.94	2.0	
	56	10	25	1.02	2.0	
	46.7	12	30	1.08	1.7	
	35	14	40	1.19	1.2	
	28	17	50	1.28	1.0	
GWM040	23.3	19	60	1.36	0.9	
	28	19	50	2.47	2.0	
	23.3	21	60	2.63	1.7	
	17.5	26	80	2.89	1.3	
	14	29	100	3.11	1.0	
	0.12kw					
	GWM030	186.7	5.2	7.5	0.68	3.4
		140	6.7	10	0.75	2.7
93.3		9.5	15	0.6	1.9	
70		12	20	0.94	1.5	
56		14	25	1.02	1.5	
46.7		16	30	1.08	1.3	
35		19	40	1.19	0.9	
28		23	50	1.28	0.8	
GWM040	46.7	17.2	30	2.08	2.6	
	35	21	40	2.29	1.9	

Model	N ₂ (r/min)	M ₂ (N.m)	i	kN	f.s.	
0.12kw						
GWM040	28	25	50	2.47	1.5	
	23.3	28	60	2.63	1.3	
	17.5	34	80	2.89	1.0	
	14	38	100	3.11	0.8	
GWM050	23.3	29	60	3.61	2.3	
	17.5	35	80	3.97	1.9	
	14	40	100	4.28	1.4	
0.18kw						
GWM030	186.7	7.8	7.5	0.68	2.3	
	140	10	10	0.75	1.8	
	93.3	14	15	0.86	1.3	
	70	18	20	0.94	1.0	
	56	21	25	1.02	1.0	
	46.7	24	30	1.08	0.8	
GWM040	70	19	20	1.82	2.0	
	56	23	25	1.96	1.7	
	46.7	26	30	2.08	1.7	
	35	32	40	2.29	1.3	
	28	38	50	2.47	1.0	
	23.3	43	60	2.63	0.8	
	35	32	40	3.15	2.3	
	28	39	50	3.39	1.9	
GWM050	23.3	43	60	3.61	1.6	
	17.5	52	80	3.97	1.2	
	14	60	100	4.28	0.9	
	0.25kw					
	GWM040	186.7	11	7.5	1.31	3.6
		140	14	10	1.44	2.8
93.3		21	15	1.65	1.9	
70		27	20	1.82	1.5	
56		32	25	1.96	1.2	
46.7		36	30	2.08	1.3	
35		44	40	2.29	0.9	
28		37	50	2.47	0.8	
70		26	20	2.50	2.7	
56		32	25	2.69	2.2	
GWM050	46.7	37	30	2.86	2.3	
	35	46	40	3.15	1.7	
	28	54	50	3.39	1.4	
	23.3	60	60	3.61	1.1	
	17.5	72	80	3.97	0.9	
	28	56	50	4.44	2.4	
GWM063	23.3	63	60	4.71	2.0	
	17.5	78	80	5.19	1.6	
	14	87	100	5.59	1.4	
	0.37kw					
GWM040	186.7	16	7.5	1.31	2.4	
	140	21	10	1.44	1.9	
	93.3	31	15	1.65	1.3	

Single Stage Reducer (Input speed 1440r/min)

Model	N ₂ (r/min)	M ₂ (N.m)	i	kN	f.s.
0.37kw					
GWM040	70	39	20	1.82	1.0
	56	47	25	1.96	0.8
	46.7	53	30	2.08	0.8
GWM050	140	21	10	1.98	3.3
	93.3	31	15	2.27	2.4
	70	40	20	2.5	1.8
	56	48	25	2.69	1.5
	46.7	55	30	2.86	1.5
	35	68	40	3.15	1.1
	28	80	50	3.39	0.9
	23.3	89	60	3.61	0.8
GWM063	35	70	40	4.12	2.1
	28	83	50	4.44	1.6
	23.3	94	60	4.71	1.4
	17.5	115	80	5.19	1.1
	14	129	100	5.59	0.9
0.55kw					
GWM050	186.7	25	7.5	1.8	2.9
	140	32	10	1.98	2.2
	93.3	46	15	2.27	1.6
	70	59	20	2.5	1.2
	56	71	25	2.69	1.0
	46.7	81	30	2.86	1.0
	35	80	40	3.13	0.9
GWM063	70	60	20	3.27	2.2
	56	73	25	3.52	1.8
	46.7	83	30	3.74	1.9
	35	105	40	4.12	1.4
	28	124	50	4.44	1.1
GWM075	23.3	140	60	4.71	0.9
	35	108	40	4.86	2.0
	28	129	50	5.24	1.6
	23.3	146	60	5.56	1.4
	17.5	180	80	6.13	1.1
GWM090	14	206	100	6.60	0.9
	17.5	189	80	6.78	1.5
	14	221	100	7.30	1.2
0.75kw					
GWM050	186.7	34	7.5	1.80	2.1
	140	44	10	1.98	1.6
	93.3	63	15	2.27	1.2
	70	81	20	2.50	0.9
GWM063	93.3	63	15	2.97	2.2
	70	83	20	3.27	1.6
	56	100	25	3.52	1.3
	46.7	114	30	3.74	1.4
	35	143	40	4.12	1.0
GWM075	56	102	25	4.16	2.0
	46.7	117	30	4.42	2.0
	35	147	40	4.86	1.5
	28	177	50	5.24	1.2
	23.3	200	60	5.56	1.0
GWM090	28	184	50	5.79	1.8
	23.3	212	60	6.16	1.5

Model	N ₂ (r/min)	M ₂ (N.m)	i	kN	f.s.
0.75kw					
GWM090	17.5	258	80	6.78	1.1
	14	302	100	7.30	0.9
1.1kw					
GWM063	186.7	49	7.5	2.35	2.6
	140	65	10	2.59	2.0
	93.3	93	15	2.97	1.5
	70	122	20	3.27	1.1
	56	146	25	3.52	0.9
	46.7	167	30	3.74	1.0
	35	165	40	3.59	0.9
	93.3	95	15	3.50	2.1
GWM075	70	123	20	3.86	1.7
	56	150	25	4.16	1.3
	46.7	171	30	4.42	1.3
	35	216	40	4.86	1.0
	28	264	50	4.60	0.9
	23.3	223	60	4.89	0.8
	35	225	40	5.38	1.6
	28	270	50	5.79	1.3
GWM090	23.3	311	60	6.16	1.0
	17.5	328	80	6.17	0.9
	28	281	50	7.32	2.3
	23.3	324	60	7.78	1.9
	17.5	402	80	8.57	1.3
GWM110	14	473	100	9.23	1.0
1.5kw					
GWM063	186.7	67	7.5	2.35	1.9
	140	89	10	2.59	1.5
	93.3	127	15	2.97	1.1
	70	166	20	3.27	0.8
GWM075	140	90	10	3.06	2.2
	93.3	130	15	3.50	1.5
	70	168	20	3.86	1.3
	56	205	25	4.16	1.0
	46.7	233	30	4.42	1.0
GWM090	70	171	20	4.27	2.1
	56	210	25	4.60	1.6
	46.7	239	30	4.89	1.7
	35	307	40	5.38	1.2
	28	368	50	5.79	0.9
	23.3	424	60	6.16	0.8
GWM110	35	319	40	6.80	2.2
	28	384	50	7.32	1.7
	23.3	442	60	7.78	1.4
	17.5	548	80	8.57	0.9
2.2kw					
GWM075	186.7	100	7.5	2.78	1.8
	140	132	10	3.06	1.5
	93.3	191	15	3.50	1.0
	70	240	20	3.38	0.9
GWM090	46.7	269	30	3.89	0.8
	186.7	101	7.5	3.08	2.9
	140	134	10	3.39	2.3
	93.3	194	15	3.88	1.9

Single Stage Reducer (Input speed 1440r/min)

Model	N ₂ (r/min)	M ₂ (N.m)	i	kN	f.s.
2.2kw					
GWM090	70	252	20	4.27	1.4
	56	308	25	4.60	1.1
	46.7	351	30	4.89	1.2
	35	433	40	4.90	1.0
	28	393	50	5.28	0.9
GWM110	70	255	20	5.39	2.5
	56	315	25	5.81	2.2
	46.7	356	30	6.18	2.0
	35	468	40	6.8	1.5
	28	563	50	7.32	1.2
GWM130	23.3	648	60	7.78	1.0
	35	468	40	8.89	2.2
	28	563	50	9.58	1.7
	23.3	648	60	10.18	1.4
	17.5	816	80	11.21	1.0
GWM150	14	869	100	10.62	0.8
	28	570	50	13.10	2.5
	23.3	657	60	13.92	1.9
	17.5	816	80	15.32	1.4
	14	960	100	16.50	1.0
3kw					
GWM075	186.7	136	7.5	2.78	1.4
	140	180	10	3.06	1.1
	93.3	261	15	3.50	0.8
GWM090	186.7	138	7.5	3.08	2.1
	140	182	10	3.39	1.7
	93.3	264	15	3.88	1.4
	70	344	20	4.27	1.0
	56	420	25	4.60	0.8
GWM110	46.7	479	30	4.89	0.9
	93.3	264	15	4.90	2.5
	70	348	20	5.39	1.9
	56	430	25	5.81	1.6
	46.7	485	30	6.18	1.5
GWM130	35	638	40	6.80	1.1
	28	767	50	7.32	0.9
	56	429	25	7.60	2.2
	46.7	491	30	8.08	2.1
	35	638	40	8.89	1.6
GWM150	28	767	50	9.58	1.3
	23.3	884	60	10.18	1.0
	17.5	1113	80	11.21	0.8
	28	777	50	13.10	1.8
	23.3	896	60	13.92	1.4
GWM150	17.5	1113	80	15.32	1.0
	14	1310	100	16.50	0.8
	4kw				
GWM075	186.7	182	7.5	2.44	1.4
	186.7	184	7.5	3.08	1.6
GWM090	140	243	10	3.39	1.3
	93.3	352	15	3.88	1.0
	70	458	20	4.27	0.8
GWM110	140	242	10	4.28	2.5
	93.3	352	15	4.90	1.9
	70	464	20	5.39	1.4

Model	N ₂ (r/min)	M ₂ (N.m)	i	kN	f.s.
4kw					
GWM110	56	573	25	5.81	1.2
	46.7	647	30	6.18	1.1
GWM130	56	573	25	7.60	1.6
	46.7	655	30	8.08	1.6
	35	851	40	8.89	1.2
	28	1023	50	9.58	1.0
GWM150	23.3	1179	60	10.18	0.8
	28	1036	50	13.10	1.4
	23.3	1195	60	13.92	1.1
GWM150	17.5	1484	80	15.32	0.8
	5.5kw				
GWM110	186.7	253	7.5	3.89	2.2
	140	334	10	4.28	1.8
	93.3	484	15	4.90	1.4
	70	638	20	5.39	0.9
	56	711	25	5.15	1.0
GWM130	140	333	10	5.60	2.5
	93.3	490	15	6.41	1.9
	70	645	20	7.06	1.4
	56	788	25	7.60	1.2
	46.7	900	30	8.08	1.2
GWM150	35	1171	40	8.89	0.9
	28	1103	50	8.51	0.8
	70	645	20	9.65	2.0
	56	788	25	10.40	1.5
	46.7	934	30	11.05	1.3
GWM150	35	1171	40	12.16	1.3
	28	1426	50	13.10	1.0
	23.3	1643	60	13.92	0.8
7.5kw					
GWM110	186.7	345	7.5	3.89	1.6
	140	455	10	4.28	1.3
	93.3	660	15	4.90	1.0
GWM130	186.7	349	7.5	5.09	2.1
	140	455	10	5.6	1.8
	93.3	668	15	6.41	1.4
	70	880	20	7.06	1.0
	56	1074	25	7.6	0.9
GWM150	46.7	1228	30	8.08	0.8
	35	1596	40	8.89	0.7
	70	880	20	9.65	1.5
	56	1074	25	10.4	1.1
	46.7	1274	30	11.05	0.9
GWM150	35	1596	40	12.16	1.0
	11kw				
GWM150	186.7	512	7.5	6.96	2.3
	140	675	10	7.66	1.8
	93.3	990	15	8.77	1.3
	70	1291	20	9.65	1.0
GWM150	56	1576	25	10.4	0.8
	15kw				
GWM150	186.7	698	7.5	6.96	1.7
	140	921	10	7.66	1.3
	93.3	1351	15	8.77	0.9
	70	1760	20	9.65	0.7

GWM Single Stage Reducer (Input speed 1440r/min)

Model	kW	N ₂ (r/min)	M ₂ (N.m)	i	kN	kN
GWM030	0.4	186.7	18	7.5	0.68	0.15
	0.3	140	18	10	0.75	0.16
	0.2	93.3	18	15	0.86	0.16
	0.2	70	18	20	0.94	0.19
	0.2	56	21	25	1.02	0.21
	0.2	46.7	20	30	1.08	0.21
	0.1	35	18	40	1.19	0.21
	0.1	28	17	50	1.28	0.21
	0.1	23.3	16	60	1.36	0.21
GWM040	0.1	17.5	13	80	1.50	0.21
	0.9	186.7	40	7.5	1.31	0.29
	0.7	140	40	10	1.44	0.33
	0.5	93.3	40	15	1.65	0.33
	0.4	70	39	20	1.82	0.35
	0.3	56	38	25	1.96	0.35
	0.3	46.7	45	30	2.08	0.35
	0.2	35	41	40	2.29	0.35
	0.2	28	39	50	2.47	0.35
GWM050	0.2	23.3	36	60	2.63	0.35
	0.1	17.5	33	80	2.89	0.35
	0.1	14	29	100	3.11	0.35
	1.6	186.7	71	7.5	1.80	0.4
	1.2	140	72	10	1.98	0.49
	0.9	93.3	74	15	2.27	0.49
	0.7	70	73	20	2.50	0.49
	0.5	56	70	25	2.69	0.49
	0.6	46.7	84	30	2.86	0.49
GWM063	0.4	35	76	40	3.15	0.49
	0.3	28	73	50	3.39	0.49
	0.3	23.3	68	60	3.61	0.49
	0.2	17.5	65	80	3.97	0.49
	0.2	14	55	100	4.28	0.49
	2.8	186.7	128	7.5	2.35	0.5
	2.2	140	130	10	2.59	0.57
	1.6	93.3	140	15	2.97	0.61
	1.2	70	135	20	3.27	0.66
GWM075	1.0	56	130	25	3.52	0.70
	1.1	46.7	160	30	3.74	0.70
	0.8	35	145	40	4.12	0.70
	0.6	28	135	50	4.44	0.70
	0.5	23.3	130	60	4.71	0.70
	0.4	17.5	122	80	5.19	0.70
	0.3	14	118	100	5.59	0.70
	4.1	186.7	185	7.5	2.78	0.70
	3.2	140	195	10	3.06	0.83
GWM075	2.3	93.3	200	15	3.50	0.85
	1.9	70	210	20	3.86	0.98
	1.5	56	200	25	4.16	0.98
	1.5	46.7	230	30	4.42	0.98

Model	kW	N ₂ (r/min)	M ₂ (N.m)	i	kN	kN
GWM075	1.1	35	220	40	4.86	0.98
	0.9	28	210	50	5.24	0.98
	0.8	23.3	200	60	5.56	0.98
	0.6	17.5	190	80	6.13	0.98
	0.5	14	180	100	6.60	0.98
GWM090	6.3	186.7	290	7.5	3.08	0.90
	5.1	140	310	10	3.39	1.08
	4.1	93.3	360	15	3.88	1.25
	2.4	56	340	25	4.60	1.27
	2.6	46.7	410	30	4.89	1.27
	1.8	35	360	40	5.38	1.27
	1.4	28	340	50	5.79	1.27
	1.1	23.3	320	60	6.16	1.27
	0.8	17.5	285	80	6.78	1.27
GWM110	0.7	14	270	100	7.30	1.27
	12	186.7	552	7.5	3.89	1.20
	9.8	140	598	10	4.28	1.46
	7.5	93.3	656	15	4.90	1.60
	5.6	70	644	20	5.39	1.70
	4.7	56	679	25	5.81	1.70
	4.5	46.7	725	30	6.18	1.70
	3.3	35	702	40	6.80	1.70
	2.6	28	660	50	7.32	1.70
GWM130	2.1	23.3	616	60	7.78	1.70
	1.4	17.5	515	80	8.57	1.70
	1.1	14	483	100	9.23	1.70
	16.1	186.7	750	7.5	5.09	1.50
	13.5	140	820	10	5.60	1.84
	10.3	93.3	920	15	6.41	2.07
	7.8	70	910	20	7.06	2.10
	6.5	56	930	25	7.60	2.10
	6.4	46.7	1040	30	8.08	2.10
GWM150	4.9	35	1050	40	8.89	2.10
	3.8	28	980	50	9.58	2.10
	3.1	23.3	900	60	10.18	2.10
	2.3	17.5	840	80	11.21	2.10
	1.7	14	740	100	12.07	2.10
	25.8	186.7	1200	7.5	6.96	1.95
	20.2	140	1240	10	7.66	2.26
	13.9	93.3	1250	15	8.77	2.28
	11.1	70	1300	20	9.65	2.67
GWM150	8.4	56	1200	25	10.40	2.80
	7.1	46.7	1200	30	11.05	2.80
	7.3	35	1550	40	12.16	2.80
	5.4	28	1400	50	13.10	2.80
	4.2	23.3	1260	60	13.92	2.80
	3.1	17.5	1150	80	15.32	2.80
	2.3	14	1000	100	16.50	2.80

IEC Shaft Dimensions

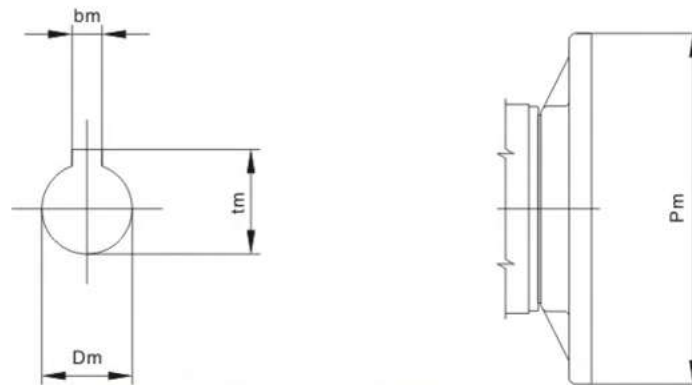

ALL DIMENSIONS IN MM

B5	IEC										
	056	063	071	080	090	100	112	132	160	180	200
Pm	120	140	160	200	200	250	250	300	350	350	400
Dm	9	11	14	19	24	28	28	38	42	48	55
bm	3	4	5	6	8	8	8	10	12	14	16
tm	10.4	12.8	16.3	21.8	27.3	31.3	31.3	41.3	45.3	51.8	59.3

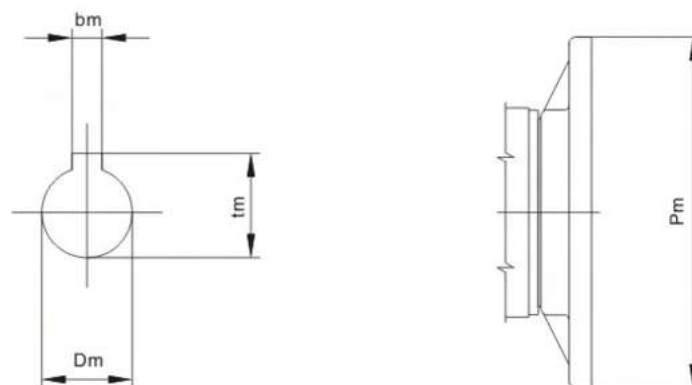

ALL DIMENSIONS IN MM

B14	IEC							
	056	063	071	080	090	110	112	132
Pm	80	90	105	120	140	160	160	200
Dm	9	11	14	19	24	28	28	38
bm	3	4	5	6	8	8	8	10
tm	10.4	12.8	16.3	21.8	27.3	31.3	31.3	41.3

GWM Dimensions

GWM025

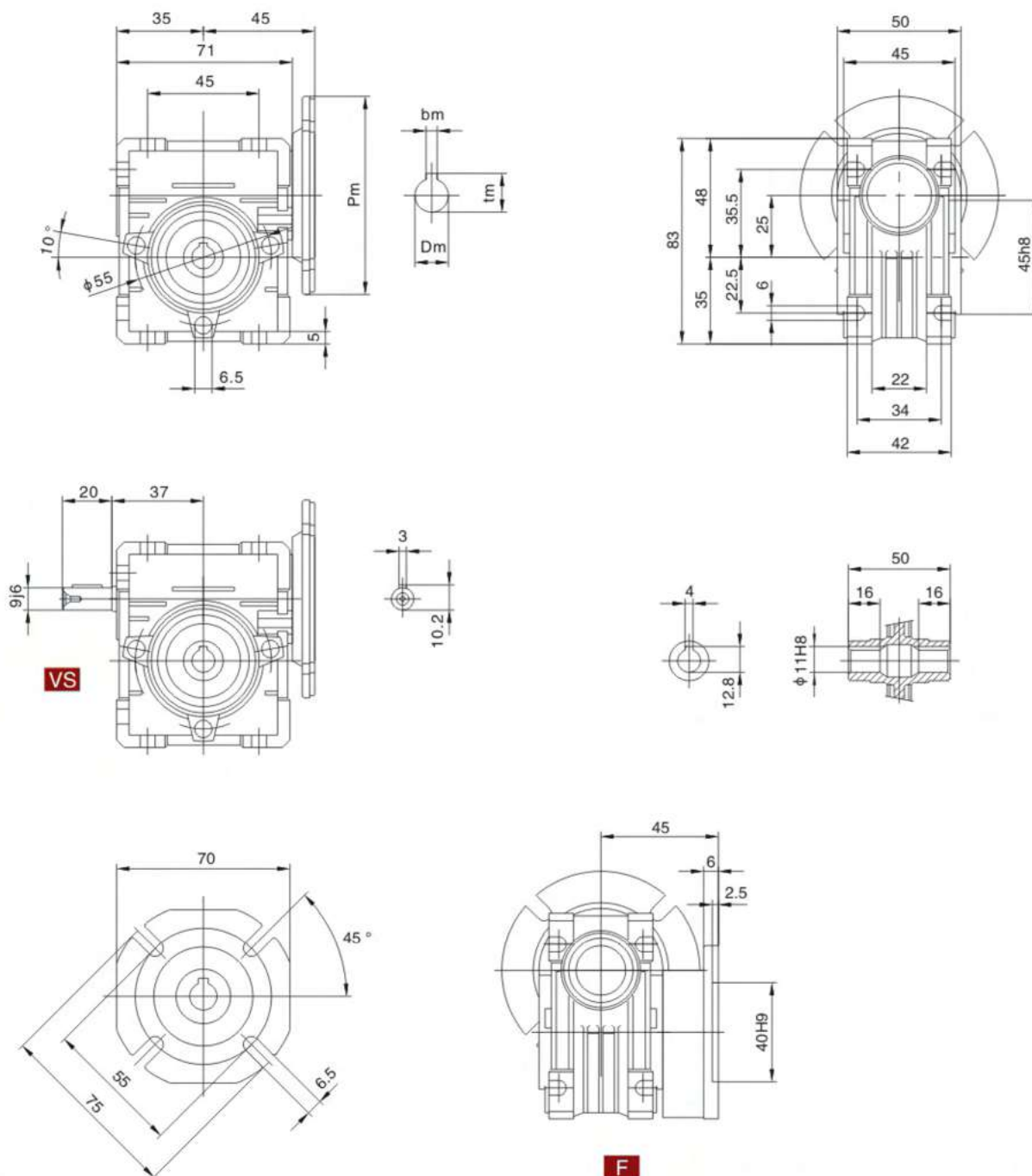

ALL DIMENSIONS ARE IN MM

*Weight without motor: 0.7kg
 *For the dimensions concerning the motor connection area (Pm,Dm,bm,tm) please refer to the table shown at page 14.

GWM030

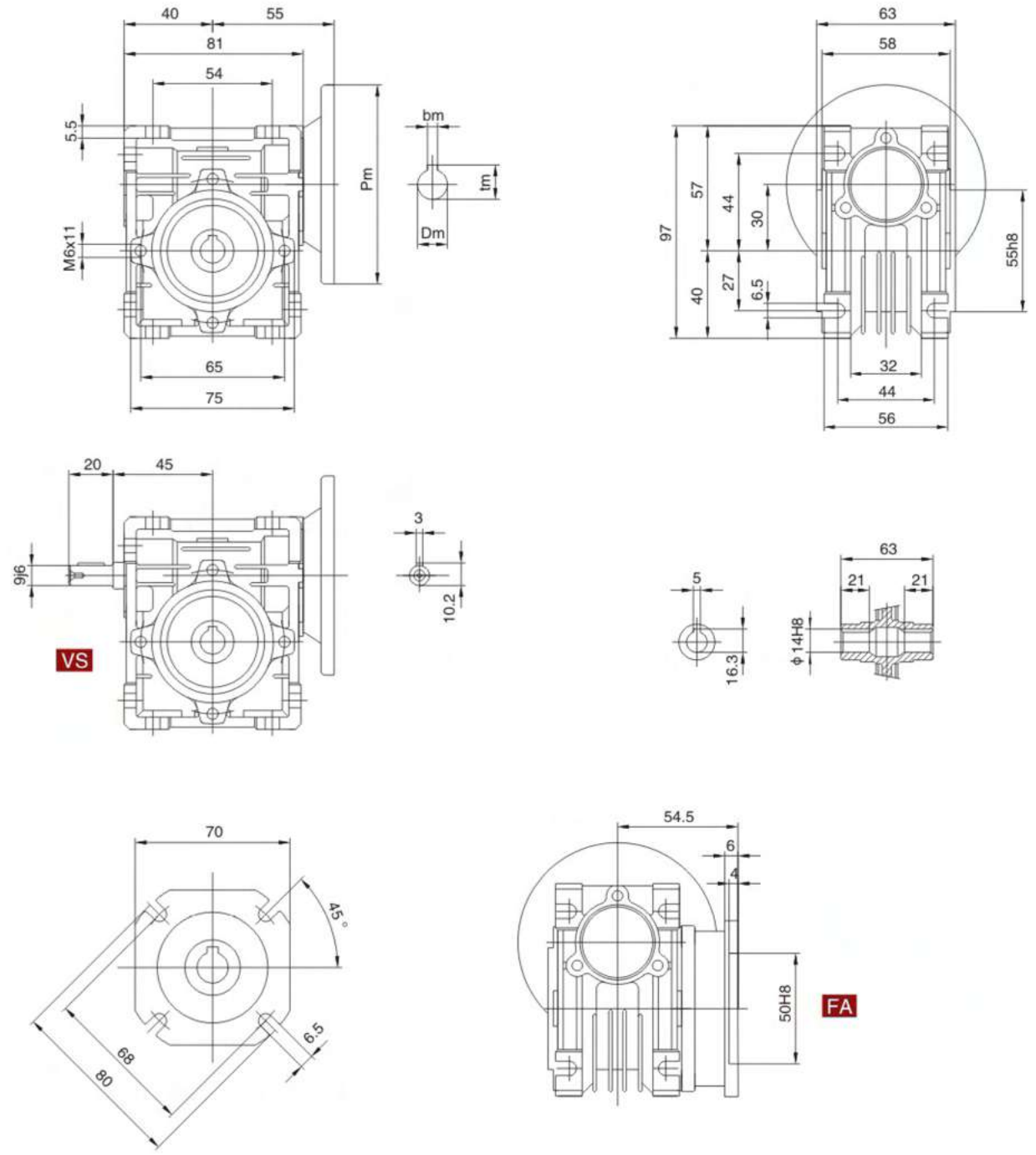

ALL DIMENSIONS ARE IN MM

*Weight without motor: 1.3kg
 *For the dimensions concerning the motor connection area (Pm,Dm,bm,tm) please refer to the table shown at page 14.

GWM040

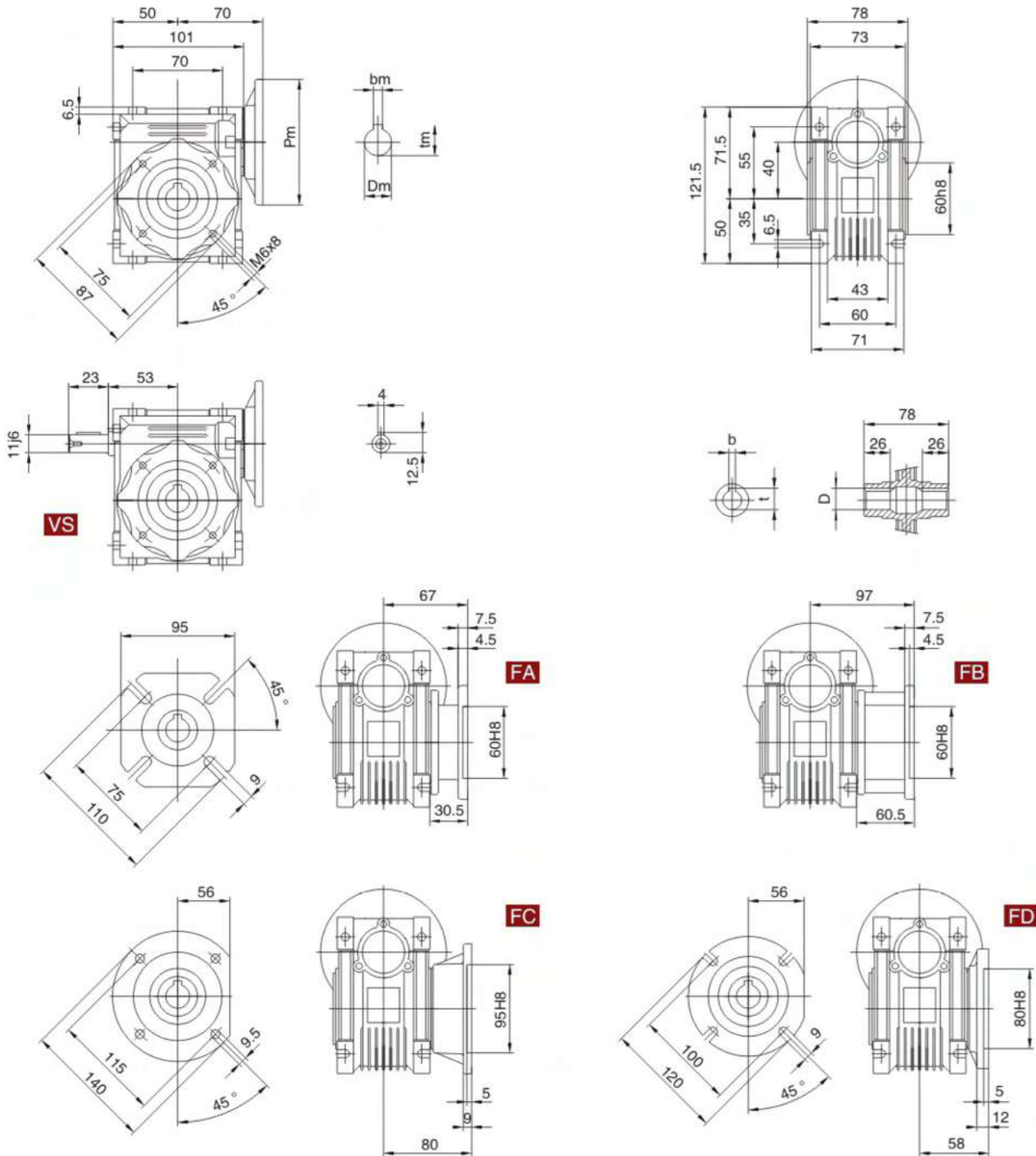

ALL DIMENSIONS ARE IN MM

Output		
D	H8	t
18	6	20.8
(19)	(6)	(21.8)

(..) Only on request

* Weight without motor: 2.3kg

* For the dimensions concerning the motor connection area (Pm, Dm, bm, tm) please refer to the table shown at page 14.

GWM050

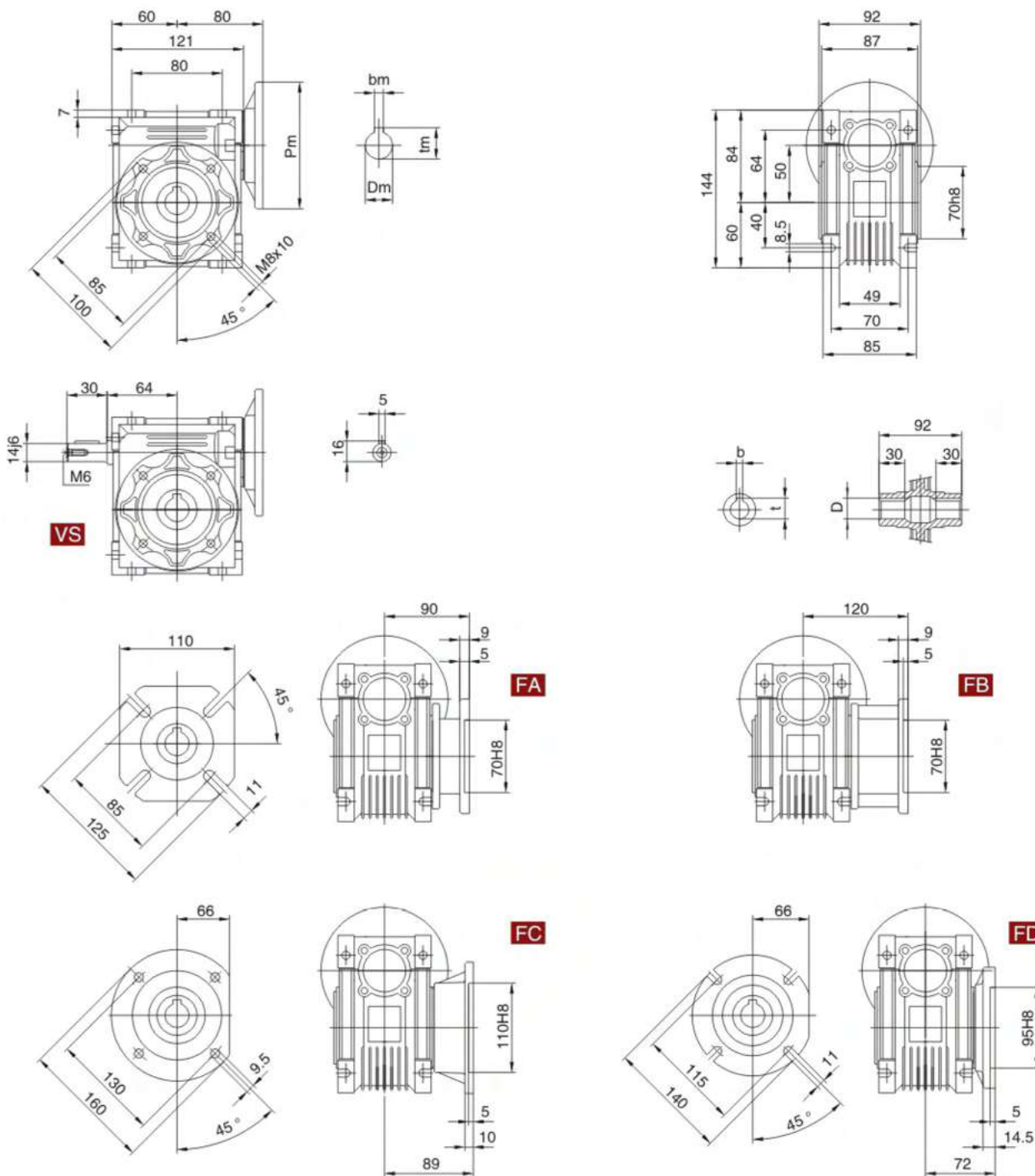

ALL DIMENSIONS ARE IN MM

Output		
D H8	b	t
25	8	28.3
(24)	(8)	(27.3)

(..) Only on request

* Weight without motor: 3.5kg

* For the dimensions concerning the motor connection area (Pm, Dm, bm, tm) please refer to the table shown at page 14.

GWM063

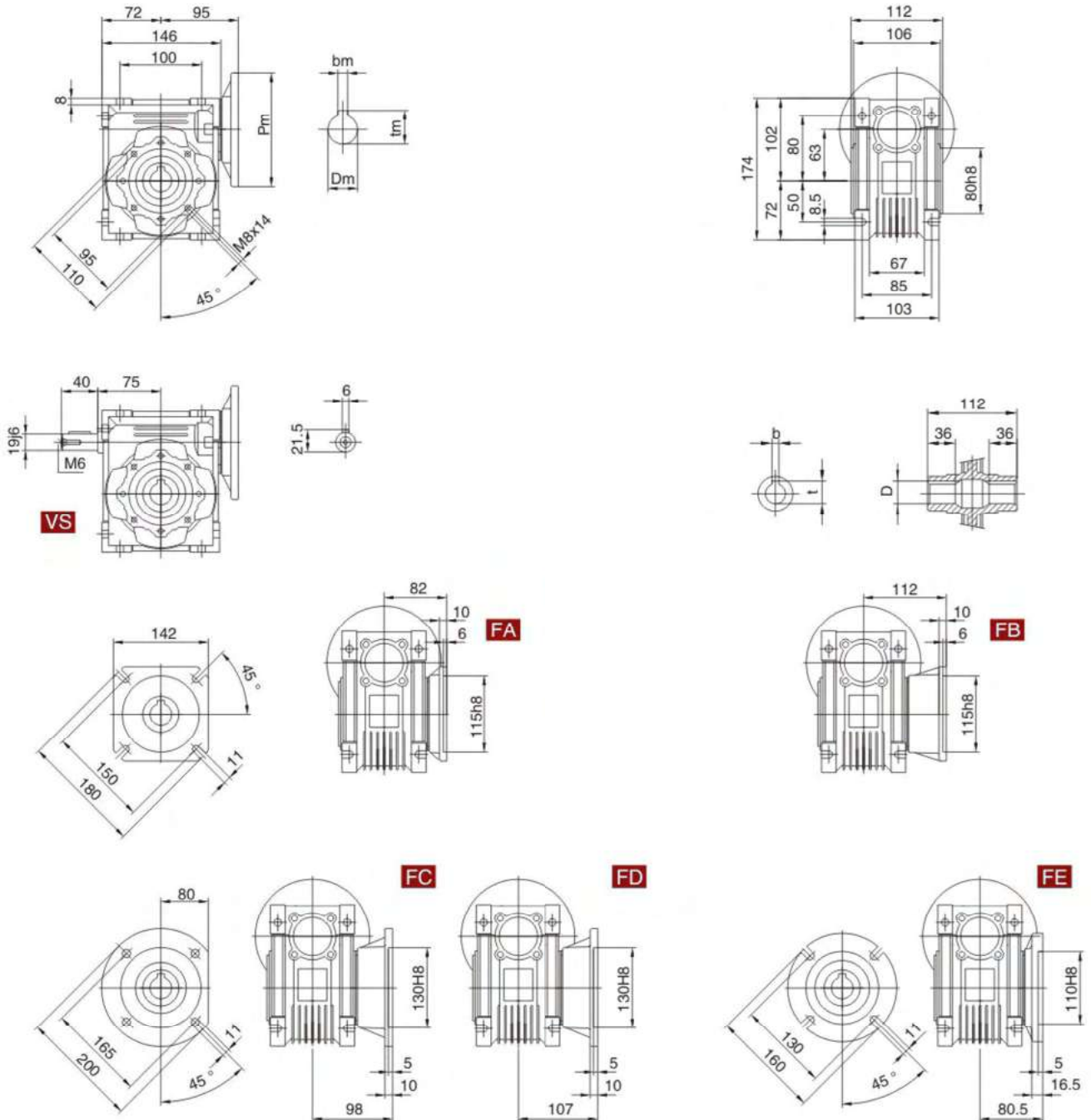

ALL DIMENSIONS ARE IN MM

Output			
D	H8	b	t
25		8	28.3
(28)		(8)	(31.3)

(..) Only on request

* Weight without motor: 6.2kg

* For the dimensions concerning the motor connection area (Pm, Dm, bm, tm) please refer to the table shown at page 14.

GWM075

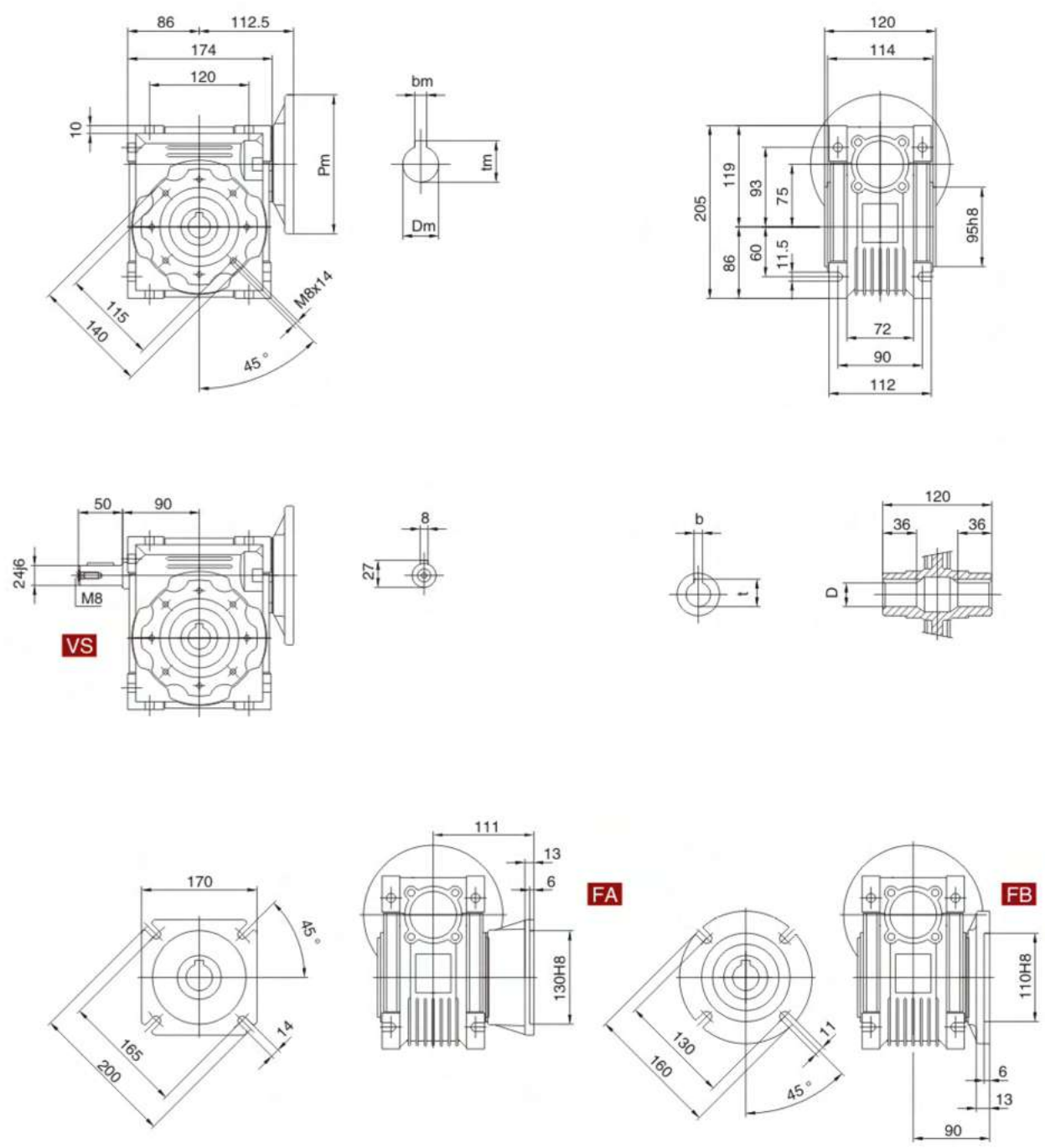

ALL DIMENSIONS ARE IN MM

Output		
D	H8	t
28	8	31.3
(35)	(10)	(38.3)

(..) Only on request
 * Weight without motor: 9kg
 * For the dimensions concerning the motor connection area (Pm,Dm,bm,tm) please refer to the table shown at page 14.

GWM090

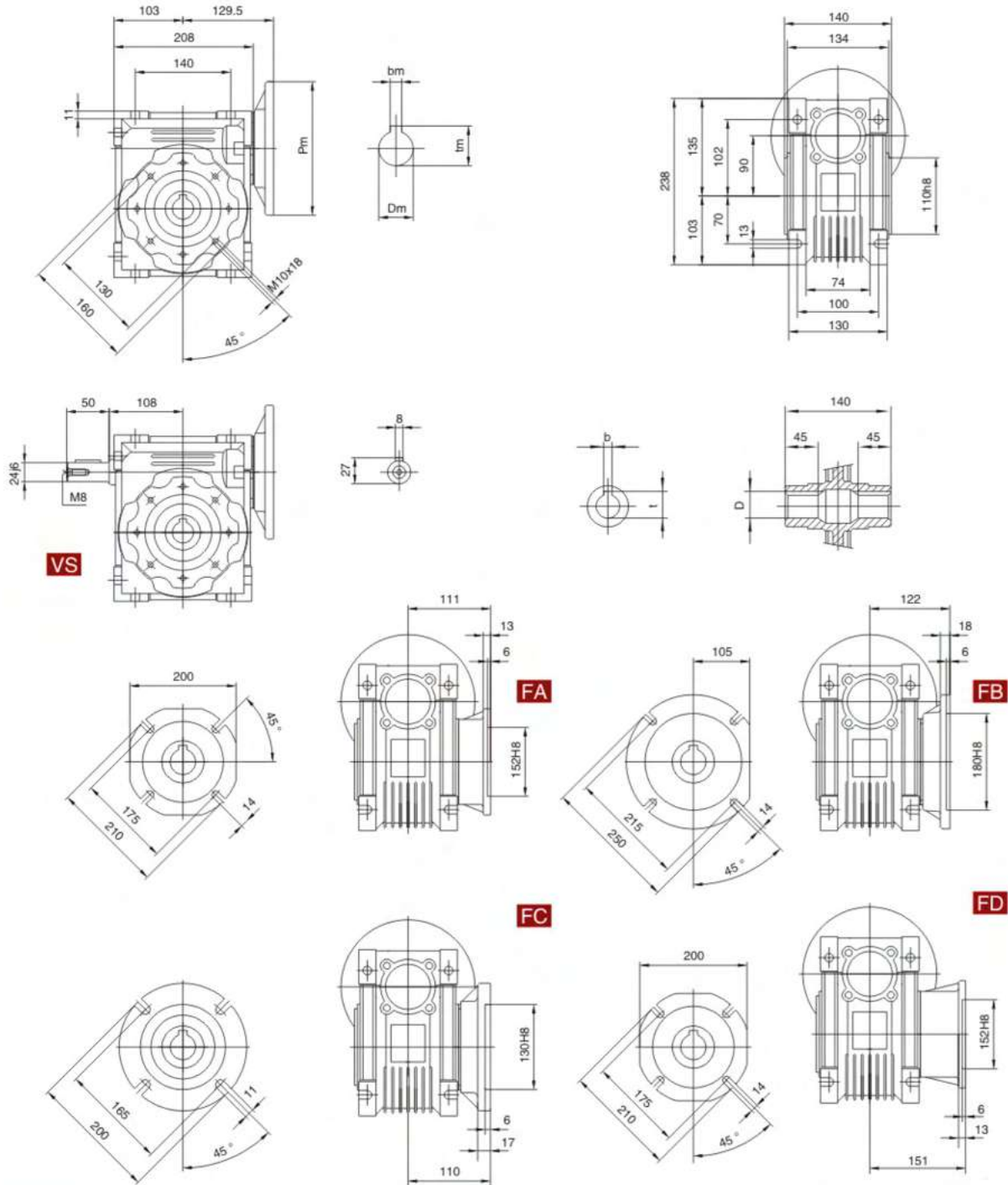

ALL DIMENSIONS ARE IN MM

Output		
D H8	b	t
35	10	38.3
(38)	(10)	(41.3)

(..) Only on request

* Weight without motor: 13kg

* For the dimensions concerning the motor connection area (Pm, Dm, bm, tm) please refer to the table shown at page 14.

GWM110

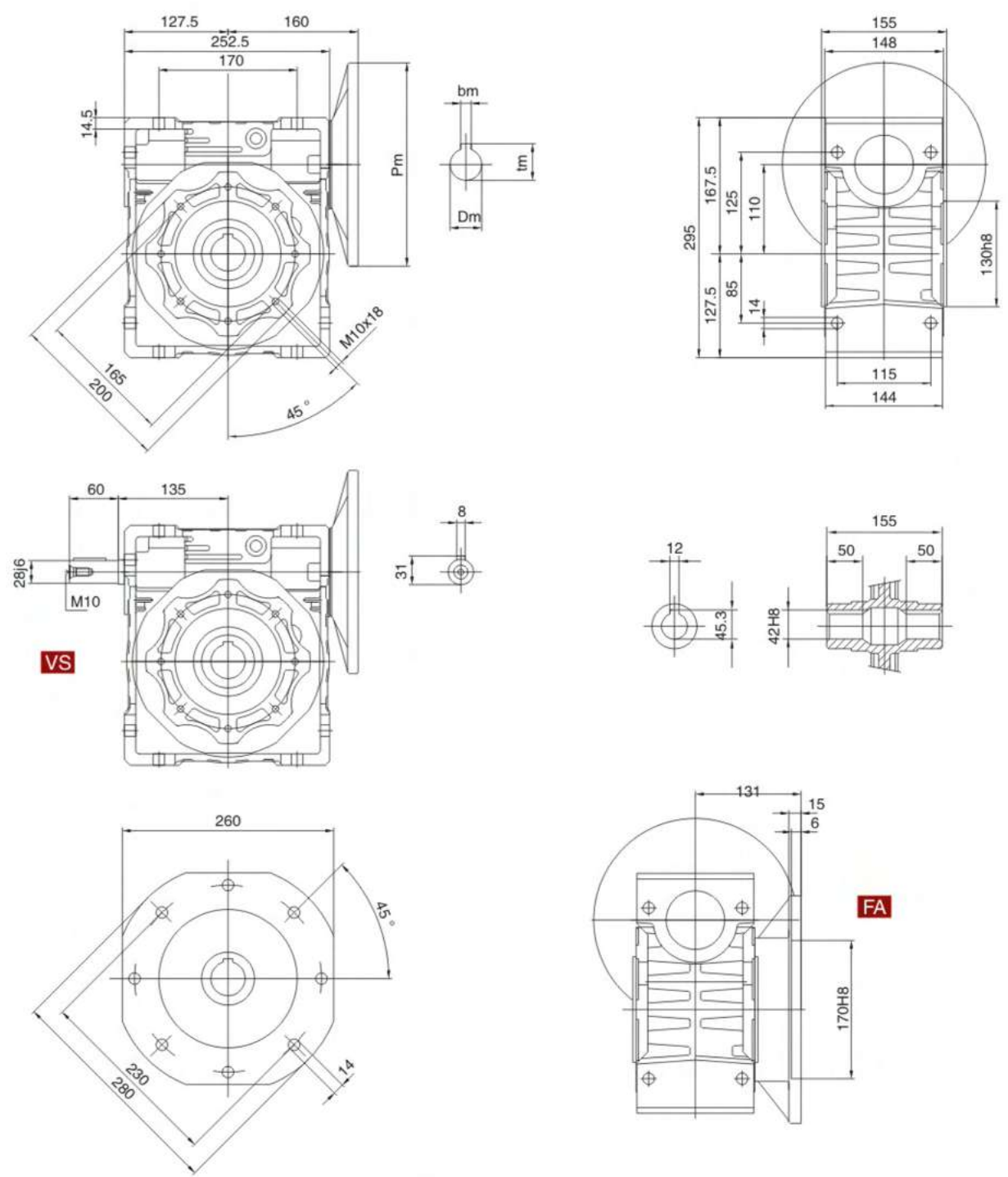

VS

FA

ALL DIMENSIONS ARE IN MM

*Weight without motor: 35kg
 *For the dimensions concerning the motor connection area (Pm,Dm,bm,tm) please refer to the table shown at page 14.

GWM130

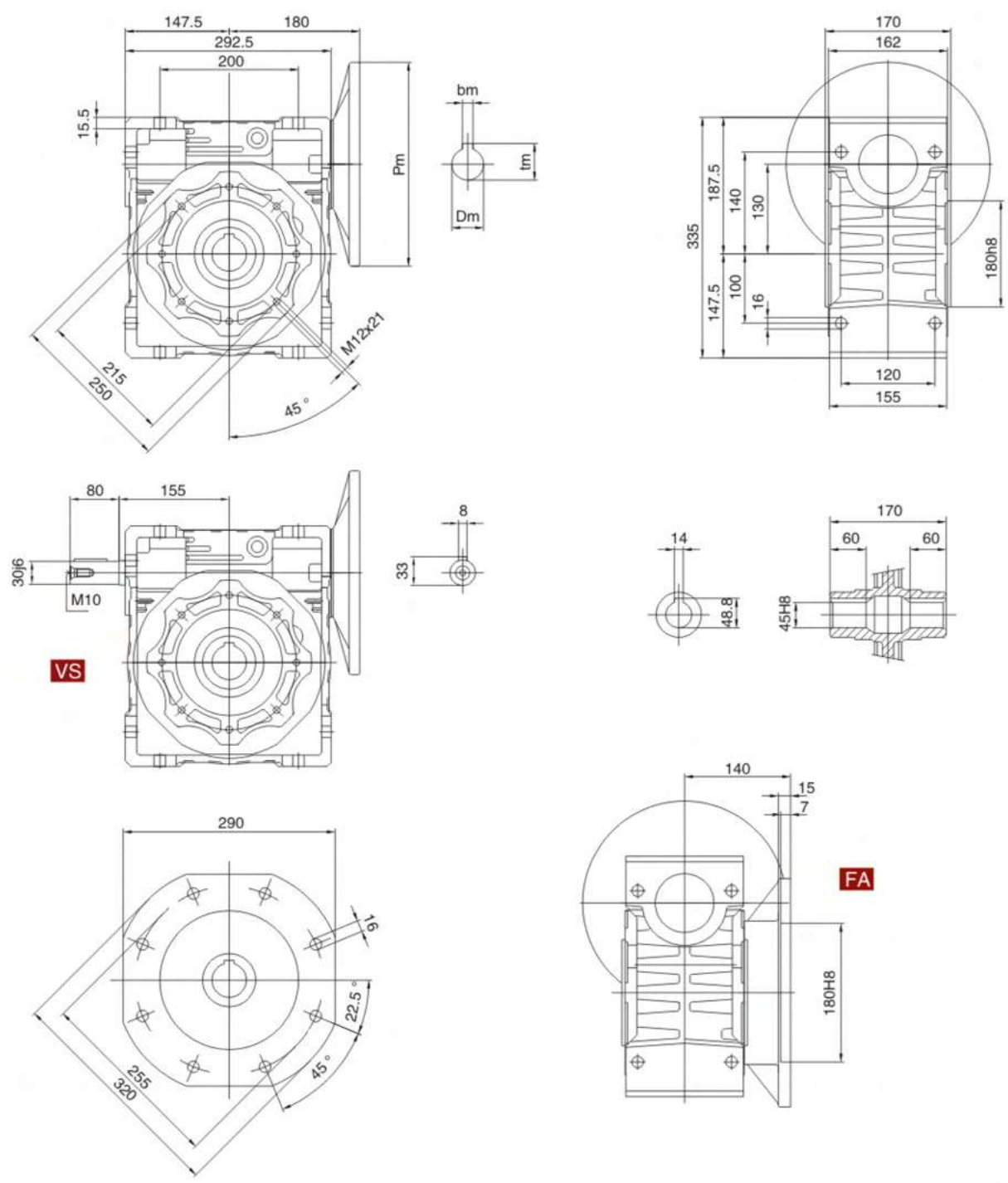

ALL DIMENSIONS ARE IN MM

*Weight without motor: 48kg
 *For the dimensions concerning the motor connection area (Pm,Dm,bm,tm) please refer to the table shown at page 14.

GWM150

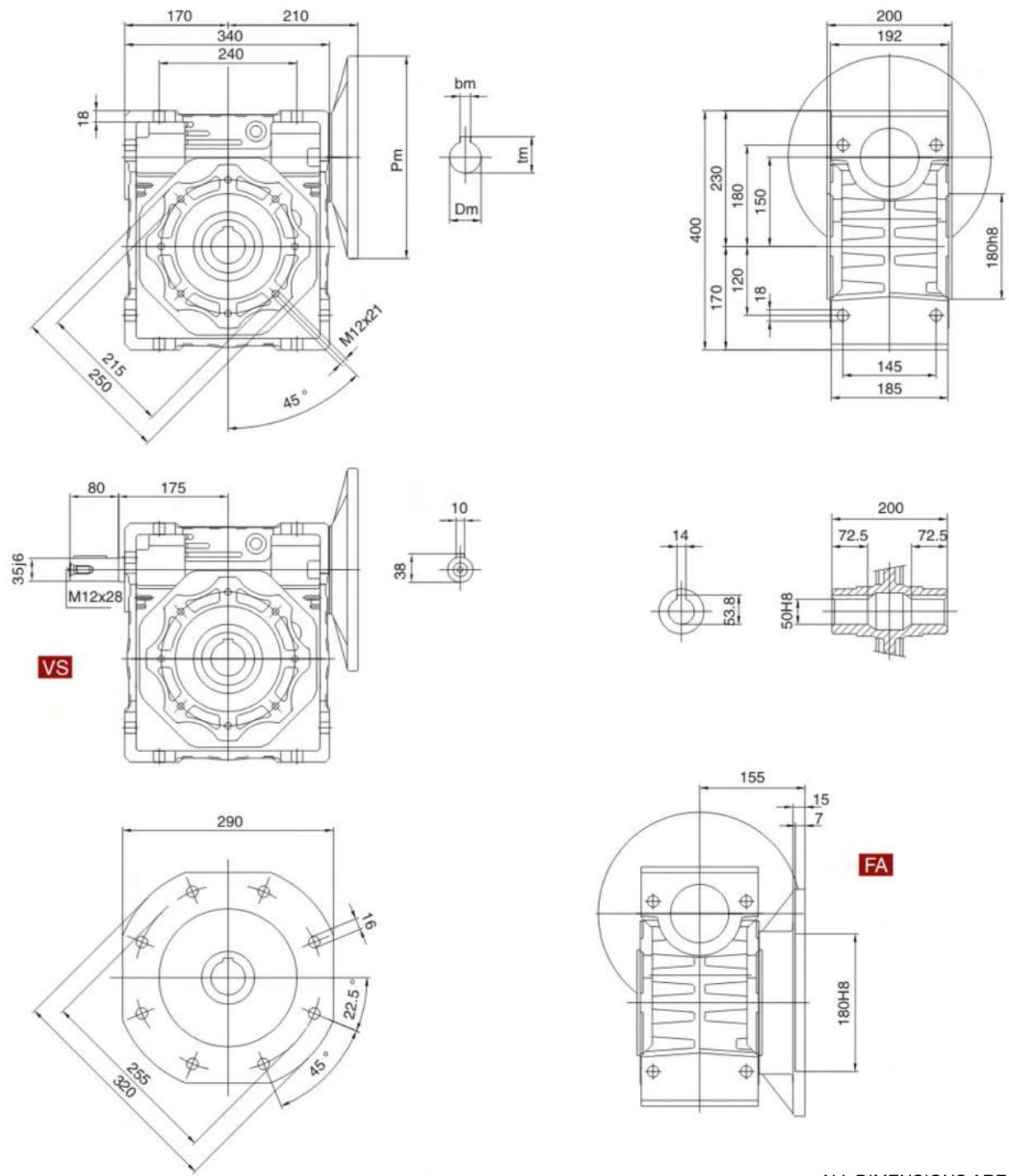

VS

FA

ALL DIMENSIONS ARE IN MM

*Weight without motor: 84kg
 *For the dimensions concerning the motor connection area (Pm,Dm,bm,tm) please refer to the table shown at page 14.

GW Dimension

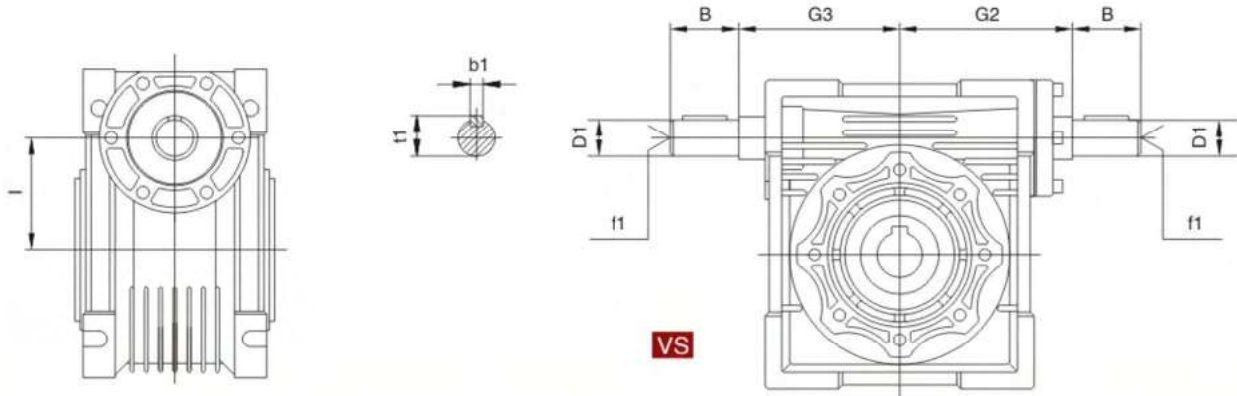

GWM	G2	G3	D1	B	F1	l	b1	t1
025	38	37	9j6	20	-	25	3	10.2
030	51	45	9j6	20	-	30	3	10.2
040	60	53	11j6	23	-	40	4	12.5
050	74	64	14j6	30	M6	50	5	16
063	90	75	19j6	40	M6	63	6	21.5
075	105	90	24j6	50	M8	75	8	27
090	125	108	24j6	50	M8	90	8	27
110	142	135	28j6	60	M10	110	8	31
130	162	155	30j6	80	M10	130	8	33
150	195	175	35j6	80	M12	150	10	38

Low Speed Shaft Dimension

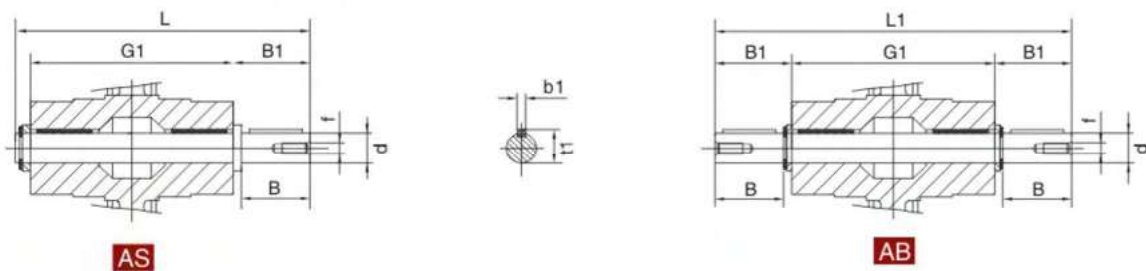

GWM	d	B	B1	G1	L	L1	f	b1	t1
025	11g6 (9)	23 (25)	25.5 (30)	50	81 (85.5)	101	-	4 (3)	12.5 (10.2)
030	14g6	30	32.5	63	102	128	M6	5	16
040	18h6	40	43	78	128	164	M6	6	20.5
050	25h6	50	53.5	92	153	199	M10	8	28
063	25h6	50	53.5	112	173	219	M10	8	28
075	28h6	60	63.5	120	192	247	M10	8	31
090	35h6	80	84.5	140	234	309	M12	10	38
110	42h6	80	84.5	155	249	324	M16	12	45
130	45h6	80	85	170	265	340	M16	14	48.5
150	50h6	82	87	200	297	374	M16	14	53.5

Only on request

ALL DIMENSIONS ARE IN MM

End Cover to Centre Dimension

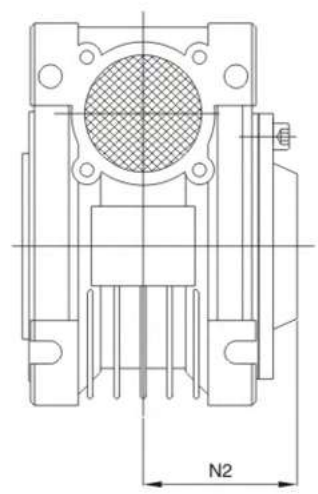

GWM	N2
030	42
040	50
050	58
063	69
075	71
090	86
105	94
110	94
130	102
150	113

Torque Arm Dimension

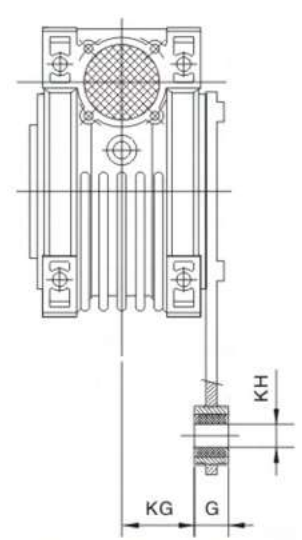
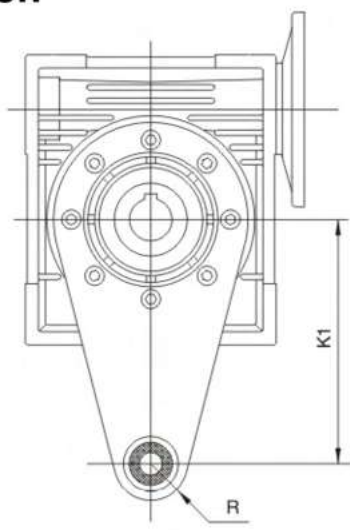

GWM	K1	G	KG	KH	R
025	70	14	17.5	8	15
030	85	14	24	8	15
040	100	14	31.5	10	18
050	100	14	38.5	10	18
063	150	14	49	10	18
075	200	25	47.5	20	30
090	200	25	57.5	20	30
110	250	30	62	25	35
130	250	30	69	25	35
150	250	30	84	25	35

ALL DIMENSIONS ARE IN MM

GWM + GW How to Order?

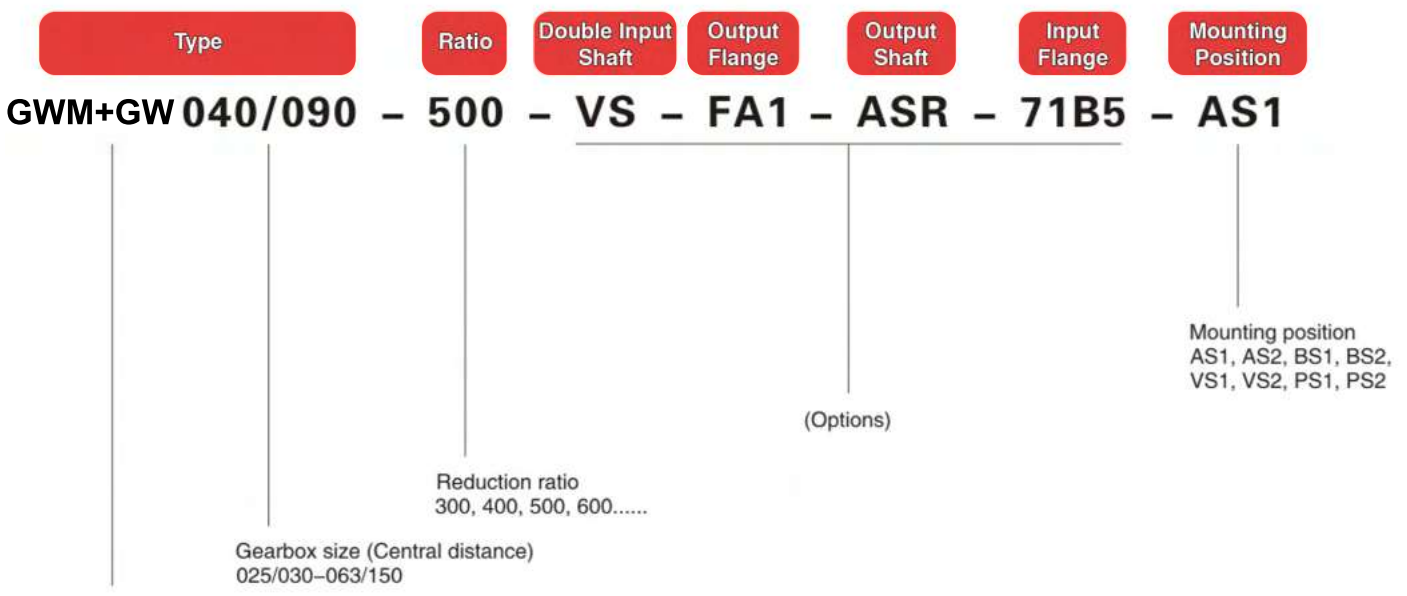
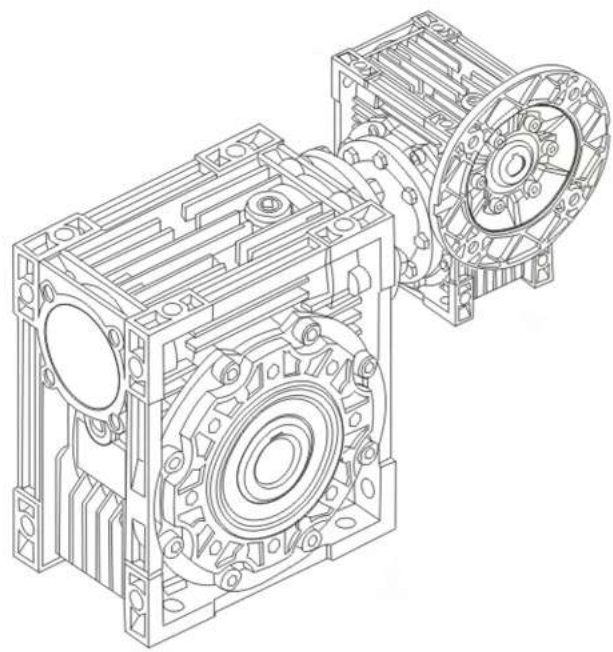

Worm gearbox type
GWM+GW- With IEC Interface
GW+GW- With Solid Input Shaft

GWM-GW Mounting Positions

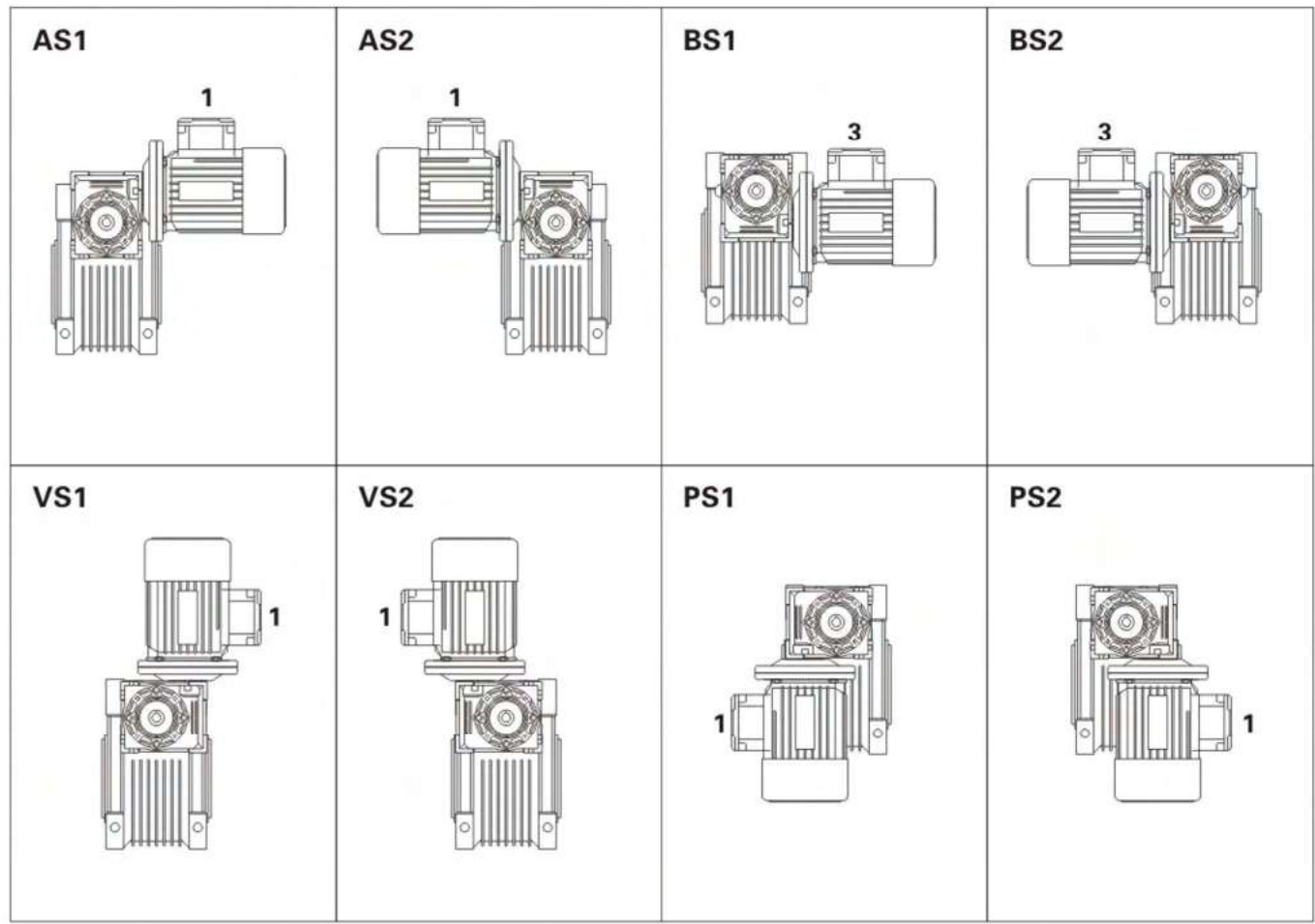

Position of Terminal Box

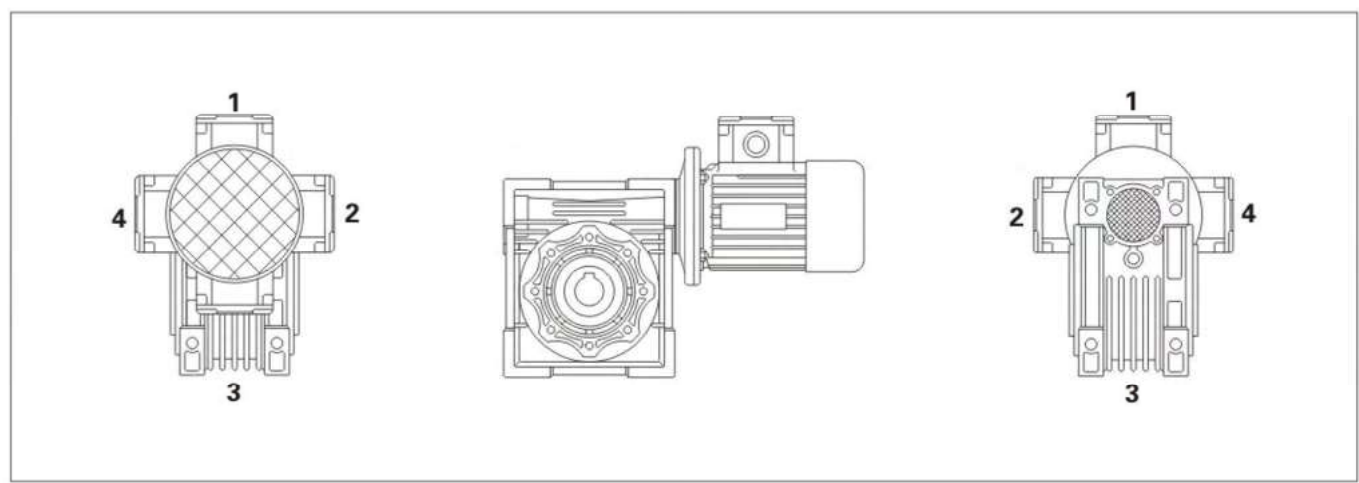

GWM+GW Rating Chart

GWM+GW Double Reduction Reducer (Input speed 1440r/min)

Model	N ₂ (r/min)	M ₂ (N.m)	i	i1	i2	kN	f.s.
0.06kw							
25/30	14	25	100	10	10	1.62	1.3
	9.3	32	150	10	15	1.83	0.9
	7.0	41	200	10	20	1.83	0.7
	5.6	44	250	10	25	1.83	0.8
25/40	4.7	59	300	10	30	3.49	1.2
	3.5	71	400	10	40	3.49	0.9
	2.8	82	500	20	25	3.49	0.7
	2.3	101	600	20	30	3.49	0.6
	1.9	116	750	25	30	3.49	0.5
	1.6	143	900	30	30	3.49	0.5
	1.2	171	1200	30	40	3.49	0.4
	0.9	197	1500	50	30	3.49	0.3
30/40	0.8	217	1800	60	30	3.49	0.3
	0.6	268	2400	60	40	3.49	0.2
	0.5	324	3000	60	50	3.49	0.2
	0.4	294	4000	50	80	3.49	0.1
	0.3	356	5000	50	100	3.49	0.1
	4.7	57	300	10	30	3.49	1.3
	3.5	70	400	10	40	3.49	0.9
	2.8	96	500	20	25	3.49	0.6
	2.3	104	600	20	30	3.49	0.7
	1.9	121	750	25	30	3.49	0.6
	1.6	139	900	30	30	3.49	0.5
	1.2	166	1200	30	40	3.49	0.4
30/50	0.9	196	1500	50	30	3.49	0.4
	0.8	218	1800	60	30	3.49	0.3
	0.58	261	2400	60	40	3.49	0.2
	0.4	300	3200	80	40	3.49	0.2
	0.4	279	4000	50	80	3.49	0.1
	0.28	338	5000	50	100	3.49	0.1
	1.6	141	900	30	30	4.84	1.0
	1.2	169	1200	30	400	4.84	0.7
	0.93	199	1500	50	30	4.84	0.7
	0.78	222	1800	60	30	4.84	0.7
30/63	0.6	266	2400	60	40	4.84	0.5
	0.5	307	3000	60	50	4.84	0.4
	0.35	288	4000	50	80	4.84	0.3
	0.29	311	4800	60	80	4.84	0.3
	0.9	203	1500	30	50	6.27	1.1
	0.78	225	1800	30	60	6.27	0.9
	0.58	276	2400	60	40	6.27	0.8
	0.47	319	3000	60	50	6.27	0.7
30/63	0.35	306	4000	50	80	6.27	0.6
	0.28	360	5000	50	100	6.27	0.4

Model	N ₂ (r/min)	M ₂ (N.m)	i	i1	i2	kN	f.s.	
0.06kw								
40/75	0.6	330	2400	60	40	7.38	1.1	
	0.47	377	3000	60	50	7.38	0.8	
	0.35	355	4000	50	80	7.38	0.7	
	0.28	419	5000	50	100	7.38	0.5	
40/90	0.5	405	3000	60	50	8.18	1.4	
	0.35	365	4000	50	80	8.18	1.3	
	0.28	431	5000	50	100	8.18	1.0	
0.09kw								
25/30	14	37	100	10	10	1.62	0.8	
	9.3	49	150	10	15	1.83	0.6	
	7.0	62	200	10	20	1.83	0.5	
	5.6	66	250	10	25	1.83	0.5	
	4.7	75	300	10	30	1.83	0.4	
	3.5	107	400	10	40	1.83	0.3	
	2.8	115	500	20	25	1.83	0.2	
	2.3	135	600	20	30	1.83	0.2	
	1.9	151	750	25	30	1.83	0.2	
	1.6	178	900	30	30	1.83	0.2	
	1.2	212	1200	30	40	1.83	0.1	
	0.9	247	1500	50	30	1.83	0.1	
30/40	0.78	304	1800	60	30	1.83	0.1	
	0.58	340	2400	60	40	1.83	0.1	
	0.47	405	3000	60	50	1.83	0.1	
	4.7	87	300	10	30	3.49	0.8	
	30/50	3.5	106	400	10	40	4.84	1.2
		2.8	123	500	10	50	4.84	1.0
		2.3	159	600	20	30	4.84	0.9
		1.9	185	750	25	30	4.84	0.8
	30/63	1.6	212	900	30	30	4.84	0.7
		1.6	200	900	15	60	6.27	1.0
1.2		263	1200	30	40	6.27	0.9	
40/75	0.93	305	1500	30	50	6.27	0.7	
	0.9	359	1500	50	30	7.38	1.1	
	0.78	404	1800	60	30	7.38	1.0	
40/90	0.58	496	2400	60	40	7.38	0.7	
	0.5	608	3000	60	50	8.18	0.9	
40/90	0.35	548	4000	50	80	8.18	0.8	
	0.12kw							
30/50	4.7	118	300	10	30	4.84	1.2	
	3.5	142	400	10	40	4.84	0.9	
	2.8	164	500	10	50	4.84	0.7	
30/63	2.8	171	500	10	50	6.27	1.3	
	2.3	208	600	15	40	6.27	1.1	
	1.9	241	750	15	50	6.27	0.9	

GWM+GW Double Reduction Reducer (Input speed 1440r/min)

Model	N ₂ (r/min)	M ₂ (N.m)	i	i ₁	i ₂	kN	f.s.
0.12kw							
40/75	1.6	324	900	30	30	7.38	1.2
	1.2	399	1200	30	40	7.38	0.9
40/90	0.78	546	1800	30	60	8.18	0.9
	0.58	695	2400	60	40	8.18	0.9
50/110	0.5	883	3000	60	50	10.32	1.2
	0.35	784	4000	50	80	10.32	1.0
	0.28	928	5000	50	100	10.32	0.8
0.18kw							
30/63	3.5	221	400	10	40	6.27	1.0
	2.8	257	500	10	50	6.27	0.8
40/75	2.3	362	600	20	30	7.38	1.1
	1.9	435	750	25	30	7.38	0.9
	1.6	487	900	30	30	7.38	0.8
40/90	1.2	629	1200	30	40	8.18	1.0
	0.93	735	1500	30	50	8.18	0.8
50/110	0.8	860	1800	60	30	10.32	1.5
	0.58	1113	2400	60	40	10.32	1.1
0.25kw							
30/63	3.5	159	400	10	40	6.27	1.4
	2.8	185	500	10	50	6.27	1.2
40/75	3.5	336	400	10	40	7.38	1.1
	2.8	384	500	10	50	7.38	0.8
40/90	2.3	511	600	15	40	8.18	1.2
	1.9	598	750	15	50	8.18	0.9
	1.6	667	900	15	60	8.18	0.8
50/110	1.2	943	1200	30	40	10.32	1.3
	0.93	1064	1500	50	30	10.32	1.2
	0.78	1195	1800	60	30	10.32	1.1
63/130	0.6	1624	2400	60	40	13.5	1.0
	0.47	1935	3000	60	50	13.5	0.8
	0.35	2046	4000	50	80	13.5	0.6
	0.28	2430	5000	50	100	13.5	0.5
63/150	0.8	1199	1800	60	30	18	1.8
	0.8	1199	1800	60	30	18	1.8
	0.6	1446	2400	60	40	18	1.8
	0.5	1713	3000	60	50	18	1.4
	0.4	2026	4000	50	80	18	0.9
	0.3	2251	5000	50	100	18	0.7
	0.3	2251	5000	50	100	18	0.7
0.37kw							
40/75	4.7	405	300	10	30	7.38	1.0
	3.5	498	400	10	40	7.38	0.7
40/90	4.7	401	300	7.5	40	8.18	1.5
	3.5	523	400	10	40	8.18	1.2
	2.8	611	500	10	50	8.18	0.9
	2.3	757	600	15	40	8.18	0.8
50/110	1.9	949	750	25	30	10.32	1.3
	1.6	1079	900	30	30	10.32	1.2
	1.2	1396	1200	30	40	10.32	0.8
63/130	0.9	1674	1500	50	30	13.5	1.1

Model	N ₂ (r/min)	M ₂ (N.m)	i	i ₁	i ₂	kN	f.s.
0.37kw							
63/130	0.78	1887	1800	60	30	13.5	0.9
63/150	0.78	1774	1800	60	30	18	1.2
	0.6	2141	2400	60	40	18	1.2
	0.5	2535	3000	60	50	18	0.9
0.55kw							
50/110	4.7	638	300	10	30	10.32	2.0
	3.5	826	400	10	40	10.32	1.4
	2.8	984	500	10	50	10.32	1.1
	2.3	1181	600	15	40	10.32	1.0
63/130	1.9	1411	750	25	30	10.32	0.9
	2.8	995	500	10	50	13.5	1.6
	1.9	1471	750	25	30	13.5	1.2
63/150	1.2	2132	1200	30	40	13.5	0.8
	0.78	2637	1800	60	30	18	0.8
0.6	3182	240	60	40	18	0.8	
0.75kw							
50/110	4.7	871	300	10	30	10.32	1.5
	3.5	1126	400	10	40	10.32	1.1
63/130	2.8	1357	500	10	50	13.5	1.1
	2.3	1631	600	15	40	13.5	1.0
	1.9	2005	750	25	30	13.5	0.9
	1.6	2283	900	30	30	13.5	0.8
63/150	2.8	1290	500	10	50	18	1.8
	2.3	1529	600	15	40	18	1.7
	1.9	1783	750	25	30	18	1.3
	1.6	2215	900	30	30	18	0.9
	1.2	2680	1200	30	40	18	1.0
1.1kw							
63/130	4.7	1312	300	10	30	13.5	1.3
	3.5	1671	400	10	40	13.5	1.0
	2.8	1991	500	10	50	13.5	0.8
63/150	9.3	752	150	10	15	18	3.1
	7.0	966	200	10	20	18	2.4
	5.6	1175	250	10	25	18	1.7
	4.7	1364	300	10	30	18	1.7
	3.5	1619	400	10	40	18	1.6
	2.8	1893	500	10	50	18	1.2
	2.3	2242	600	15	40	18	1.2
1.9	2616	750	25	30	18	0.9	
1.5kw							
63/130	4.7	1789	300	10	30	13.5	1.0
	3.5	2279	400	10	40	13.5	0.7
63/150	9.3	1026	150	10	15	18	2.3
	7	1317	200	10	20	18	1.8
	5.6	1602	250	10	25	18	1.3
	4.7	1860	300	10	30	18	1.3
	3.5	2208	400	10	40	18	1.2
	2.8	2582	500	10	50	18	0.9
	2.3	3057	600	15	40	18	0.9

GWM+GW Double Reduction Reducer (Input speed 1440r/min)

Model	kW	N ₂ (r/min)	M ₂ (N.m)	i	kN	Sf
30/40	0.1	4.7	73	300	3.49	0.21
	0.1	3.5	65	400	3.49	0.21
	0.08	2.8	61	500	3.49	0.21
	0.06	2.3	73	600	3.49	0.21
	0.04	1.9	73	750	3.49	0.21
	0.03	0.6	73	900	3.49	0.21
	0.02	1.2	65	1200	3.49	0.21
	0.02	0.9	73	1500	3.49	0.21
	0.02	0.8	73	1800	3.49	0.21
	0.01	0.58	65	2400	3.49	0.21
	0.01	0.4	65	3200	3.49	0.21
	0.01	0.35	33	4000	3.49	0.21
	0.01	0.28	29	5000	3.49	0.21
30/50	0.15	4.7	145	300	4.84	0.21
	0.1	3.5	124	400	4.84	0.21
	0.1	2.8	120	500	4.84	0.21
	0.1	2.3	145	600	4.84	0.21
	0.1	1.9	145	750	4.84	0.21
	0.1	1.6	145	900	4.84	0.21
	0.08	1.2	124	1200	4.84	0.21
	0.06	0.93	145	1500	4.84	0.21
	0.04	0.78	145	1800	4.84	0.21
	0.03	0.6	124	2400	4.84	0.21
	0.02	0.5	120	3000	4.84	0.21
	0.02	0.35	82	4000	4.84	0.21
	0.02	0.29	82	4800	4.84	0.21
30/63	0.24	4.7	230	300	6.27	0.21
	0.2	3.5	230	400	6.27	0.21
	0.2	2.8	216	500	6.27	0.21
	0.13	2.3	230	600	6.27	0.21
	0.11	1.9	216	750	6.27	0.21
	0.1	1.6	198	900	6.27	0.21
	0.1	1.2	230	1200	6.27	0.21
	0.1	0.93	216	1500	6.27	0.21
	0.1	0.78	198	1800	6.27	0.21
	0.1	0.58	230	2400	6.27	0.21
	0.08	0.47	216	3000	6.27	0.21
	0.06	0.35	172	4000	6.27	0.21
	0.04	0.28	150	5000	6.27	0.21

Model	kW	N ₂ (r/min)	M ₂ (N.m)	i	kN	Sf
40/75	0.4	4.7	390	300	7.38	0.35
	0.3	3.5	360	400	7.38	0.35
	0.21	2.8	320	500	7.38	0.35
	0.2	2.3	390	600	7.38	0.35
	0.2	1.9	390	750	7.38	0.35
	0.14	1.6	390	900	7.38	0.35
	0.11	1.2	360	1200	7.38	0.35
	0.1	0.93	390	1500	7.38	0.35
	0.1	0.78	390	1800	7.38	0.35
	0.1	0.58	360	2400	7.38	0.35
	0.1	0.47	320	3000	7.38	0.35
	0.08	0.35	250	4000	7.38	0.35
	0.06	0.28	230	5000	7.38	0.35
40/90	0.6	4.7	610	300	8.18	0.35
	0.43	3.5	610	400	8.18	0.35
	0.34	2.8	560	500	8.18	0.35
	0.3	2.3	610	600	8.18	0.35
	0.23	1.9	560	750	8.18	0.35
	0.2	1.6	505	900	8.18	0.35
	0.2	1.2	610	1200	8.18	0.35
	0.14	0.93	560	1500	8.18	0.35
	0.11	0.78	505	1800	8.18	0.35
	0.11	0.58	610	2400	8.18	0.35
	0.1	0.47	560	3000	8.18	0.35
	0.1	0.35	460	400	8.18	0.35
	0.1	0.28	410	5000	8.18	0.35
50/110	1.1	4.7	1265	300	10.32	0.49
	0.8	3.5	1185	400	10.32	0.49
	0.61	2.8	1100	500	10.32	0.49
	0.6	2.3	1185	600	10.32	0.49
	0.5	1.9	1265	750	10.32	0.49
	0.43	1.6	1265	900	10.32	0.49
	0.31	1.2	1186	1200	10.32	0.49
	0.3	0.93	1265	1500	10.32	0.49
	0.3	0.78	1265	1800	10.32	0.49
	0.2	0.58	1185	2400	10.32	0.49
	0.15	0.47	1100	3000	10.32	0.49
	0.13	0.35	819	4000	10.32	0.49
	0.1	0.28	746	5000	10.32	0.49

GWM+GW Double Reduction Reducer (Input speed 1440r/min)

Model	kW	N ₂ (r/min)	M ₂ (N.m)	i	kN	Sf
63/130	0.8	2.3	1650	600	13.5	0.7
	0.7	1.9	1760	750	13.5	0.7
	0.6	1.6	1760	900	13.5	0.7
	0.4	1.2	1650	1200	13.5	0.7
	0.4	0.93	1760	1500	13.5	0.7
	0.4	0.93	1760	1500	13.5	0.7
	0.3	0.78	1760	1800	13.5	0.7
	0.3	0.58	1650	2400	13.5	0.7
	0.2	0.47	1550	3000	13.5	0.7
	0.1	0.35	1220	4000	13.5	0.7
	0.1	0.28	1100	5000	13.5	0.7

Model	kW	N ₂ (r/min)	M ₂ (N.m)	i	kN	Sf
63/150	3.4	9.3	2340	150	18	0.7
	2.7	7.0	2340	200	18	0.7
	1.9	5.6	2050	250	18	0.7
	1.9	4.7	2340	300	18	0.7
	1.8	3.5	2670	400	18	0.7
	1.4	2.8	2330	500	18	0.7
	1.3	2.3	2670	600	18	0.7
	1.0	1.9	2330	750	18	0.7
	0.7	1.6	2100	900	18	0.7
	0.7	1.2	2670	1200	18	0.7
	0.4	0.8	2100	1800	18	0.7
	0.5	0.6	2670	2400	18	0.7
	0.3	0.5	2330	3000	18	0.7
	0.2	0.4	1880	4000	18	0.7
	0.2	0.3	1650	5000	18	0.7

GWM+GW Dimensions

GWM025+ GW030

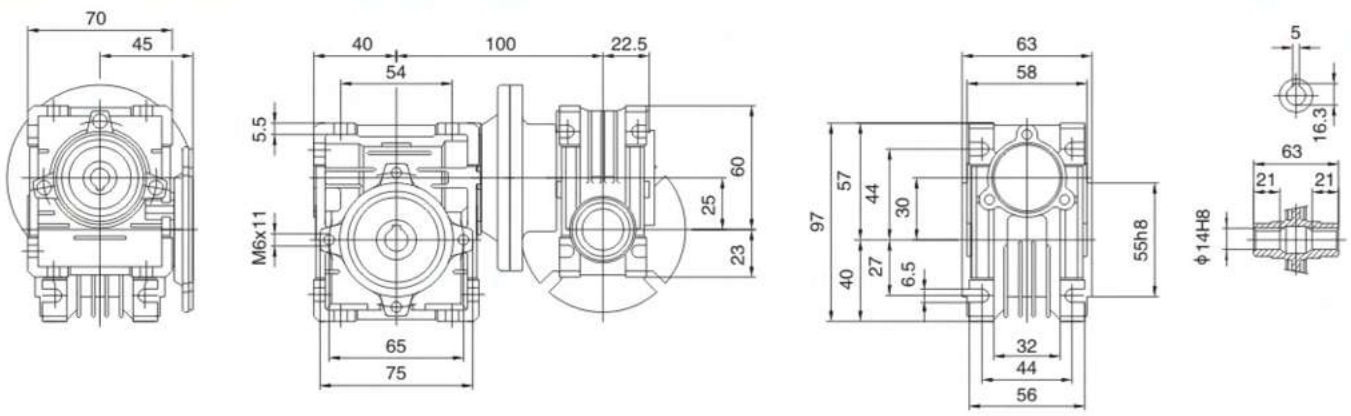

GWM025+GW040

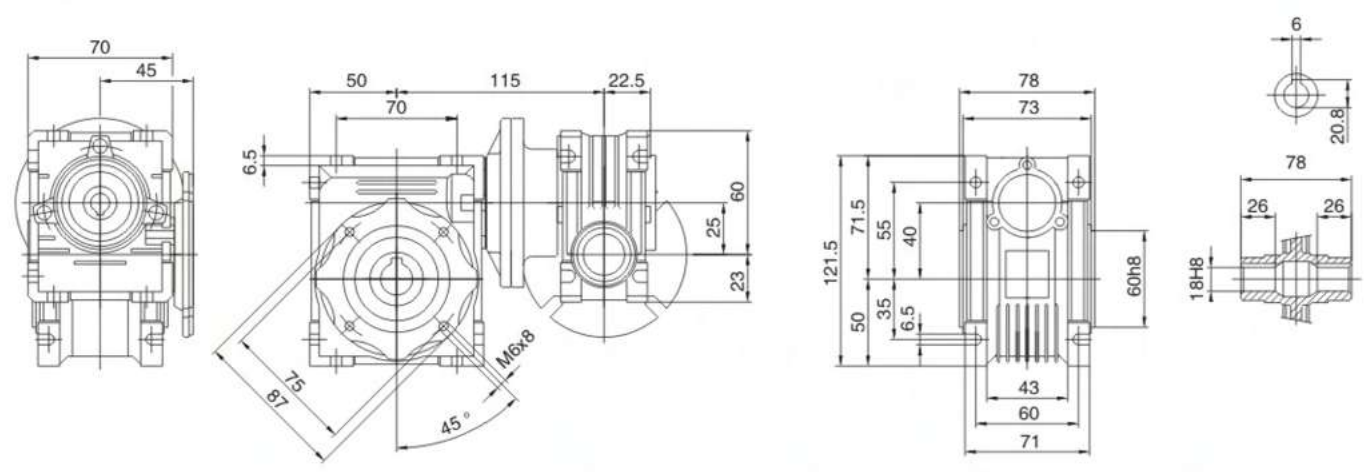

GWM025+GW040

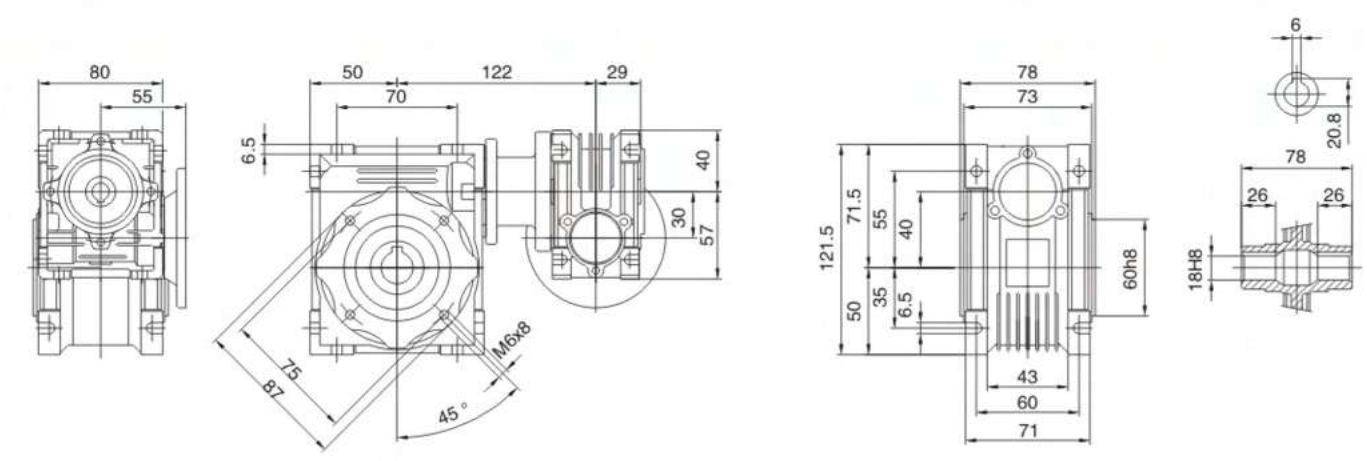

ALL DIMENSIONS ARE IN MM

GWM+GW Dimensions

GWM030+GW050

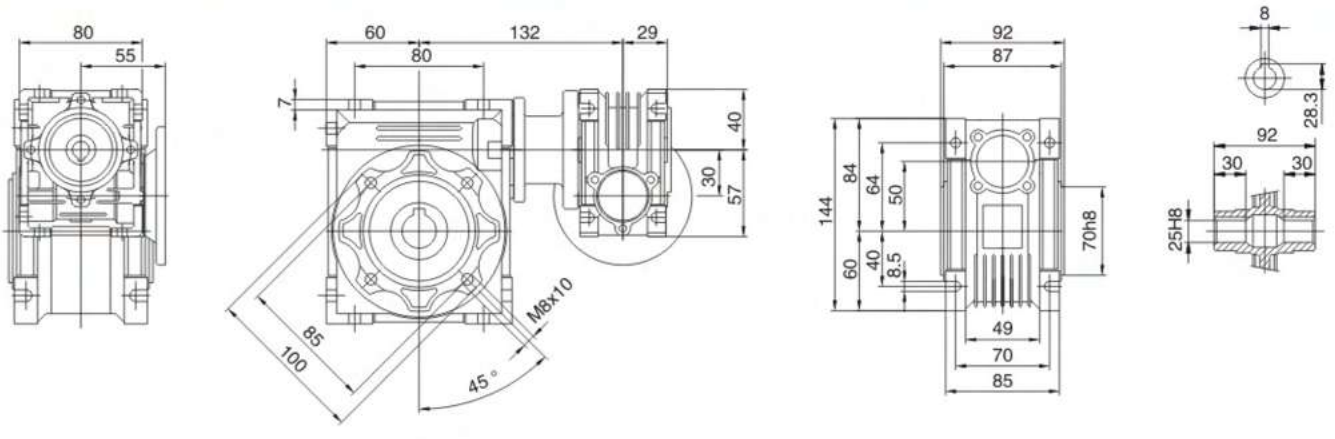

GWM030+GW063

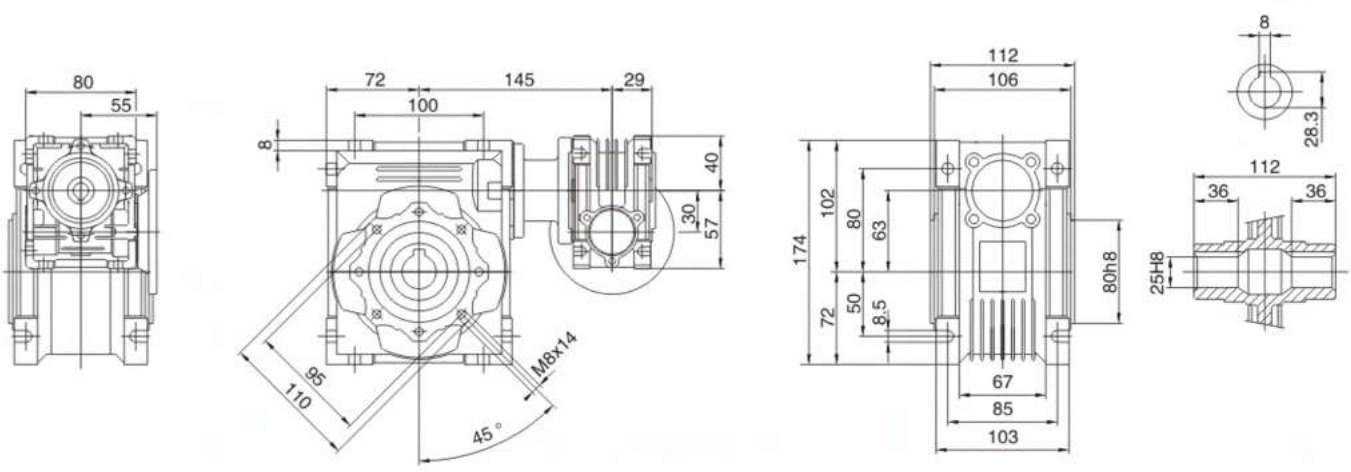

GWM040+GW075

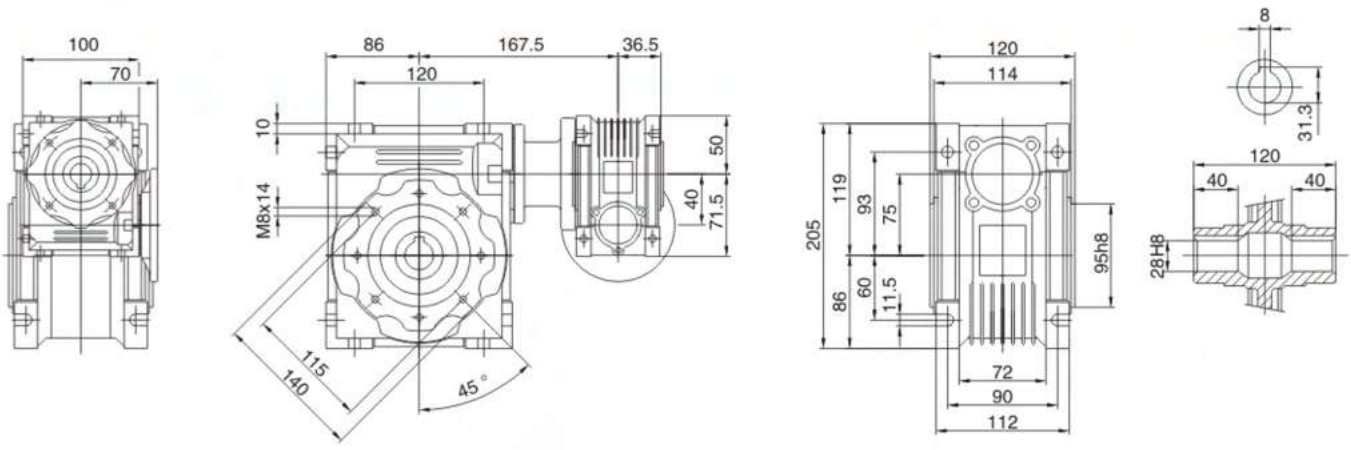

ALL DIMENSIONS ARE IN MM

GWM+GW Dimensions

GWM040+GW090

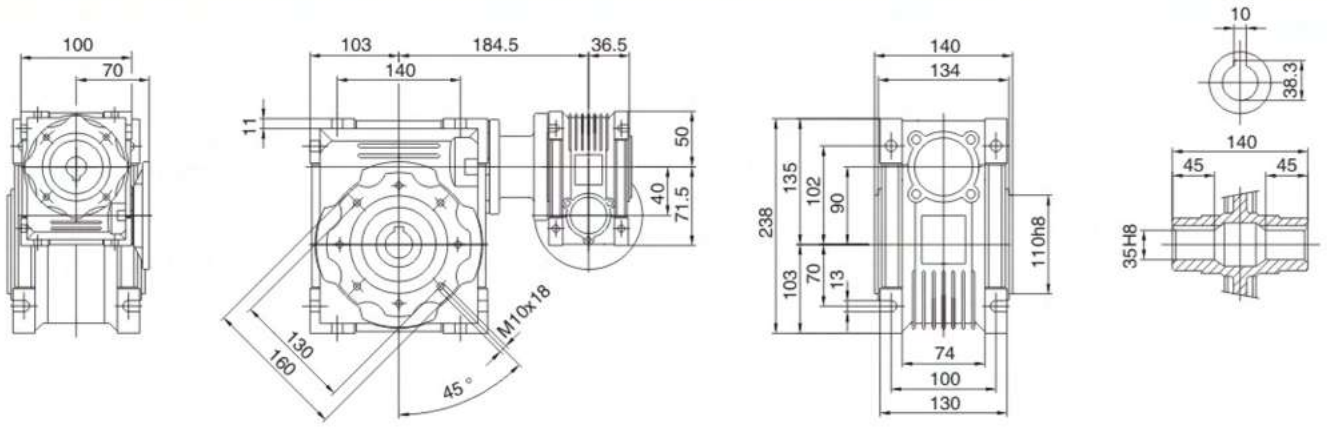

GWM050+GW110

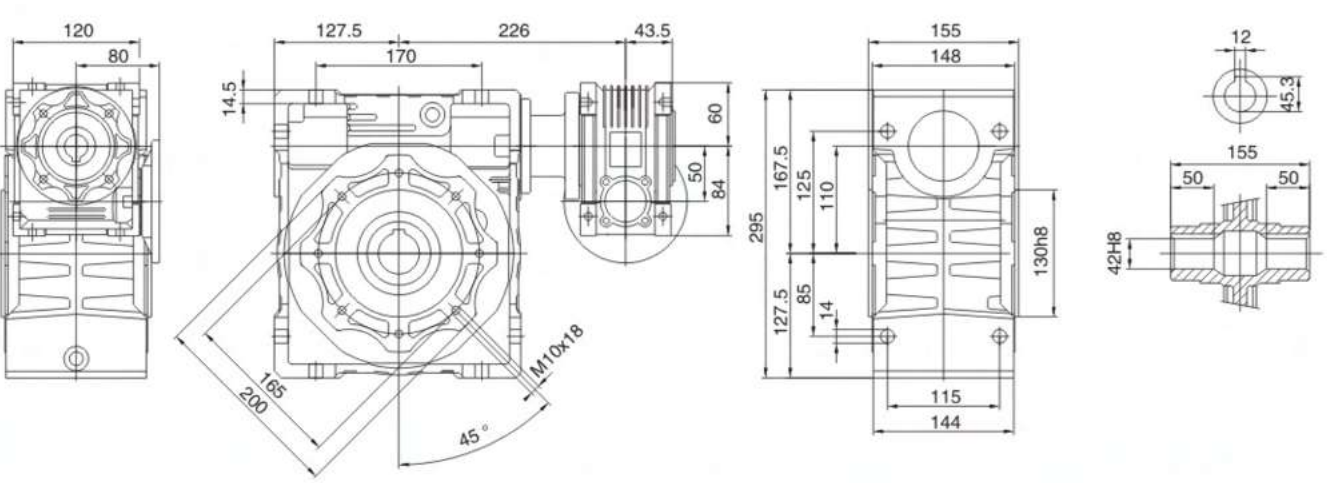

GWM063+GW130

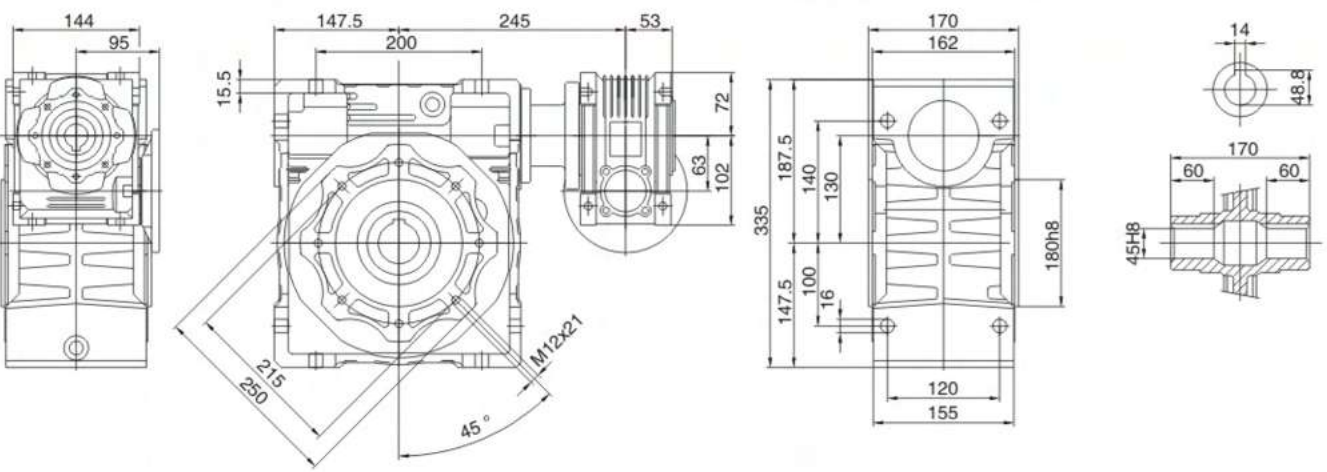

ALL DIMENSIONS ARE IN MM

GWM+GW Dimensions

GWM063+GW150

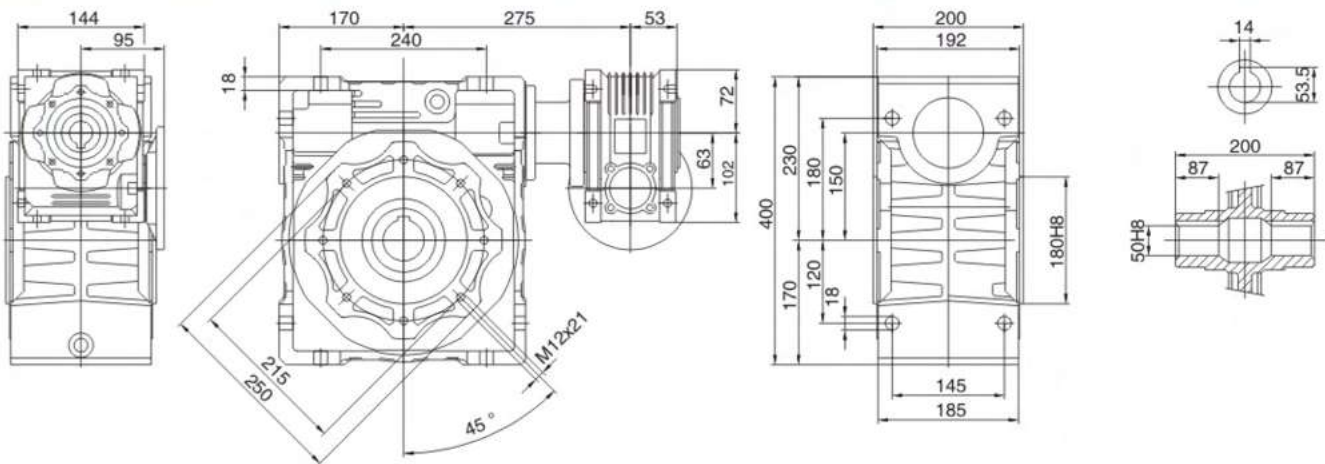

GWM+GW Dimensions

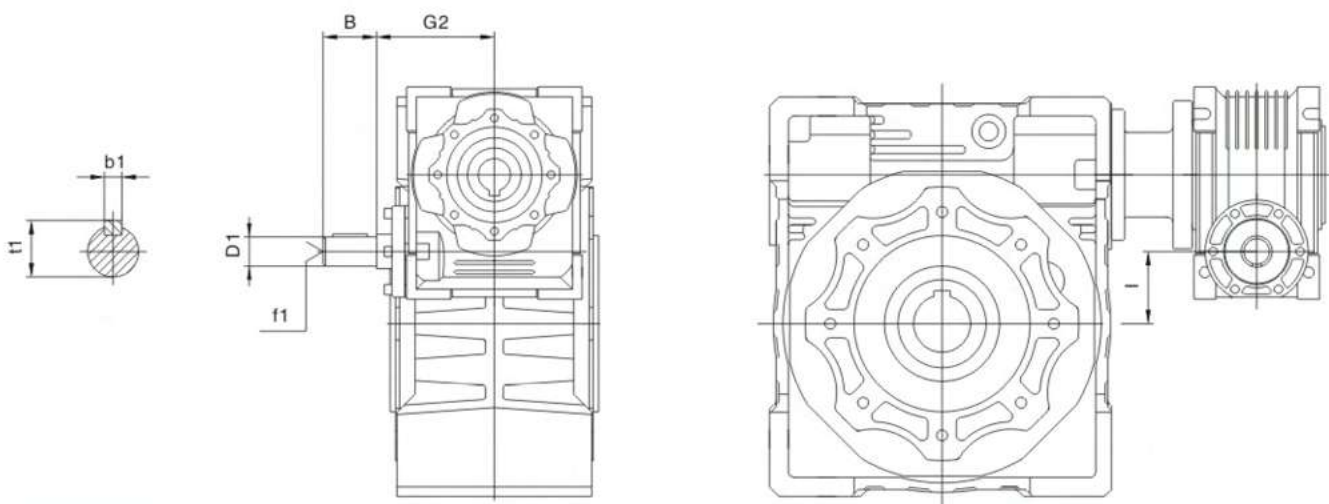

GWM+GW	030+040	030+050	030+063	040+075	040+090	050+110	063+130	063+150
B	20	20	20	23	23	30	40	40
D1	9 j6	9 j6	9 j6	11 j6	11 j6	14 j6	19 j6	19 j6
G2	51	51	51	60	60	74	90	90
l	10	20	33	35	50	60	67	87
b1	3	3	3	4	4	5	6	6
f1	-	-	-	-	-	M6	M6	M6
t1	10.2	10.2	10.2	12.5	12.5	16	21.5	21.5

ALL DIMENSIONS ARE IN MM

EXPLODED VIEW AND PART LIST

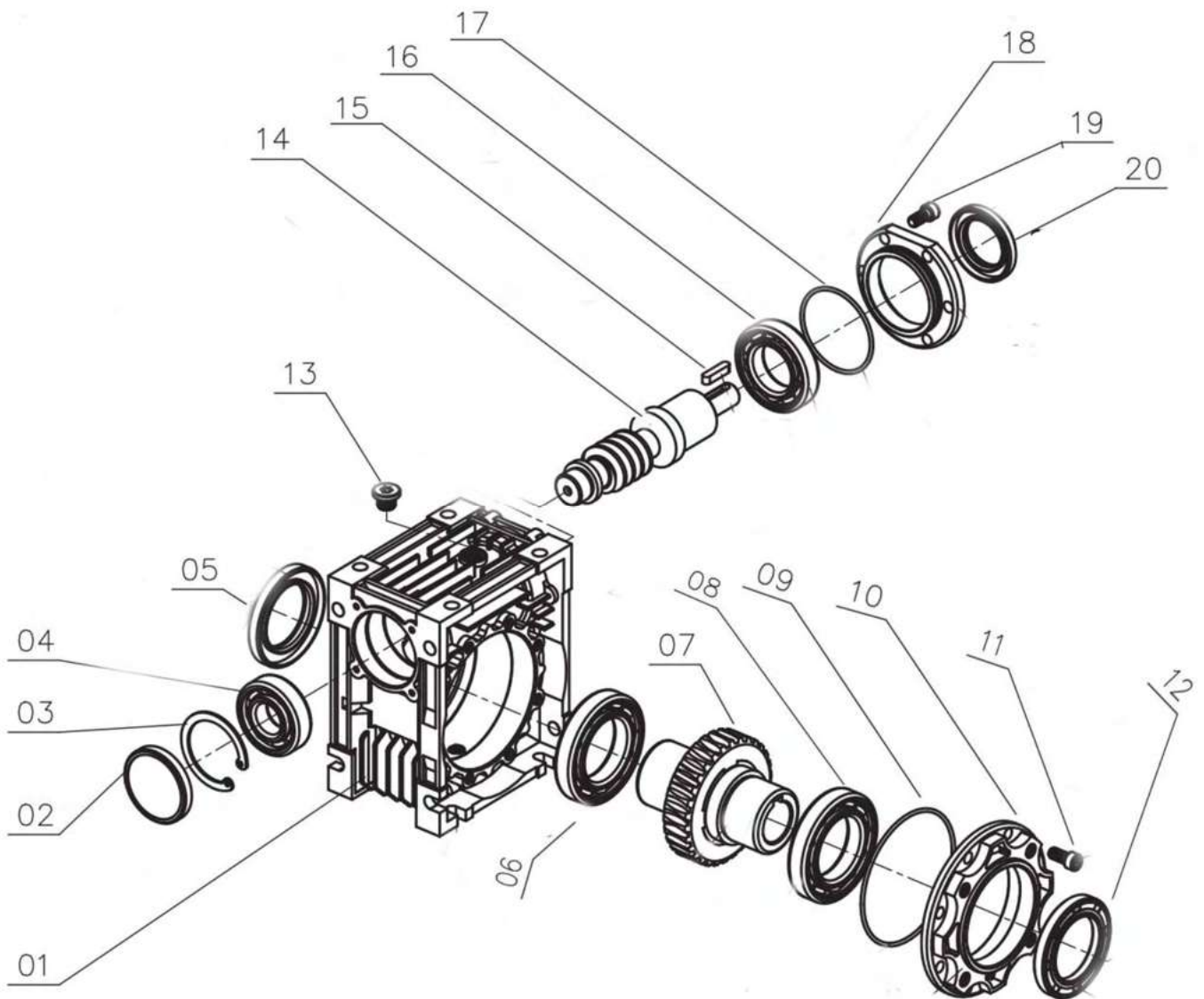

Part Code	Description	Part Code	Description	Part Code	Description	Part Code	Description
01	Casing	06	Output Bearing	11	Inner Hex Screw	16	Input Bearing
02	Bore Seal	07	Worm Wheel	12	Output Oil Seal	17	Input O Ring
03	Hole Circlip	08	Output Bearing	13	Oil Plug	18	Input Cover
04	Input Bearing	09	Output O Ring	14	Solid Input Shaft	19	Inner Hex Screw
05	Output Oil Seal	10	Side Cover	15	Flat Key Input	20	Input Oil Seal

Lubricant

Lubrication Oil Chosen Table

Reducer size	25-90	110-150	
Type of lubrication oil	Synthetic lubrication oil	Mineral lubrication oil	
Ambient temperature °C	-25 ~ +50	-5 ~ +40	-15 ~ +25
ISO VG	ISO VG 320	ISO VG 460	ISO VG 220
AGIP	TELIUM VSF320	BLASIA 460	BLASIA 220
SHELL	TIVELA OIL Sc320	OMALA OIL 460	OMALA OIL220
ESSO	S220	SPARTAN EP460	SPARTAN EP220
MOBIL	GLYGOYLE 30	MOBIL GEAR 634	MOBIL GEAR 630
CASTROL	ALPHASYN PG320	ALPHA MAX 460	ALPHA MAX 220
BP	ENERGOL SG-XP320	ENERGOL GR-XP460	ENERGOL GR-XP220

Adding Capacity of Lubrication Oil

Type Installation	025	030	040	050	063	075	090	110	130	150
B3	0.02	0.04	0.08	0.15	0.3	0.55	1	3	4.5	7
B6 B7								2.2	3.3	5.1
B8								2.5	3.5	5.4
V5								3	4.5	7
V6								2.2	3.3	5.1

Lubrication Oil Chart

Life lubricated gearboxes do not require any periodical oil changes.

For other types of gearboxes, the oil must be first changed after approx. 300 hours of operation, care-fully flushing the gear unit using suitable detergents.

Do not mix mineral oils with synthetic oils.

Check oil level regularly and change oil at the intervals shown in the table.

Oil temperature [°C]	Oil change interval [h]	
	Mineral Oil	Synthetic Oil
< 65	8000	25000
65 - 80	4000	15000
80 - 95	2000	12500

General Complaints and Solutions.

Fault description	Reasons	Solutions
Overheating	<ul style="list-style-type: none"> • Improper assembly of a prime mover with reducer and reducer with the equipment. • Overloading. • Timely replacement of lubricating oil. • Over friction on the oil seal area. • Lubricant oil level more or less than required. • Impure lubricant oil or the oil inside the sump is contaminated. 	<ul style="list-style-type: none"> • Check for radial and axial alignment. Do not use a hammer, always use a gentle push or wooden mallet. While commissioning, splash a few drops of lubricant at the oil seal area. • Fill in the proper quantity of oil and check the level at regular intervals. Keep the oil level as per the catalog. • Top up oil or replacing oil in time according to the level prescribed in the catalog.
Vibration	<ul style="list-style-type: none"> • Improper assembly of a prime mover with reducer and reducer with the equipment. • Tooth surface of a worm wheel or worm worn-out or damaged bearing, or worn-out bearing balls. • Play in input or output shaft. 	<ul style="list-style-type: none"> • Check for radial and axial alignment. Do not use a hammer, always use a gentle push or wooden mallet. • Replace worm gear sets (if required, Gaeyah will help you in fixing the parts). • Replace bearing tighten the screw. It's a good practice to use a single brand bearing in a gearbox.
Noise	<ul style="list-style-type: none"> • Improper assembly of a prime mover with reducer and reducer with the equipment. • Bearing damaged or increased backlash leading to large clearance in worm gear set mesh. • Lubricant oil shortage. 	<ul style="list-style-type: none"> • Adjust shaft play or check the bearing condition and if required replace them at both the ends. • Mend tooth surface or replace worm gear set (please contact Gaeyah). • Fill an adequate quantity of oil as per the lubricant capacity table in the catalog.
Oil Leakage	<ul style="list-style-type: none"> • Worn-out oil seal lip. • Shaft oil seal area worn-out or oil screw plugs are loose. • Oil level indicator damaged. 	<ul style="list-style-type: none"> • Replace oil seal (preferably seals with less silicon content). • Replace the worm shaft or output shaft. Properly tighten the oil screw plug. • Replace the indicator.
Often tooth surface of worm gear set is worn out	<ul style="list-style-type: none"> • Overload. • Lubricant oil quantity not in-line with the requirement or lubricant oil shortage. • Not replacing lubricant oil in time according to the prescribed manual or using contaminated oil continuously. 	<ul style="list-style-type: none"> • Adjust the load on the equipment. The demand torque should be less than the gearbox rated capacity. Replace proper lubricant oil, fill adequate oil as per level plug. In the gearbox case, if the running temperature is high, change lube oil frequently.
	<ul style="list-style-type: none"> • Over-heating while running. 	<ul style="list-style-type: none"> • Top up oil or replacing oil in time according to the requirement. • Timely replacement of lubrication oil. <ol style="list-style-type: none"> 1. Deal with it as per overheating recommendation. 2. Properly ventilating the gear unit or by decongesting the area allowing a free flow of air.

Note: If you experience any other problem which is not mentioned above, please contact us. Our company will adequately advise you through consultation and service.

Service Factor

The service factor (f.s.) depends on the operating conditions the gearbox is subjected to. Following parameters need to be taken to select the right service factor.

- type of load of the operating machine A– B–C
- length of daily operating time: hours/day(Δ)
- start-up frequency: starts/hour (*)

TYPE OF LOAD:

- A – uniform, $f_a \leq 0.3$
- B – moderate shocks, $f_a \leq 3$
- C – heavy shocks, $f_a \leq 10$

$f_a = J_{ex} \cdot J_m$

- $J_{ex}(\text{kgm}^2)$ moment of the external inertia reduced at the drive shaft
- $J_m(\text{kgm}^2)$ moment of inertia of motor

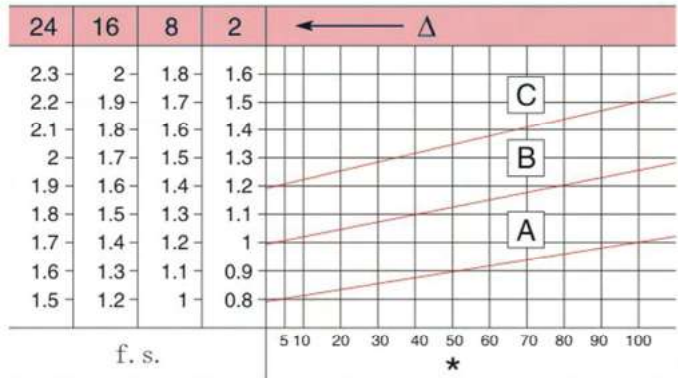

Installation Notes:

1. The gear unit must be mounted firm and stable on the machine to avoid vibration.
2. Before fitting the gear unit to the machine, check the direction of rotation of the gear unit output shaft.
3. For long time storage beyond six months of manufacture, ensure the gear unit is filled with oil to avoid oil seal sticking to the shaft. The oil seal also prone to malfunction as it may lose its elasticity. In such a case, once in a month, rotate the gear unit input shaft till the output shaft completes one rotation.
4. For a shaft mounting of a reduction unit with a hollow output shaft, use the torque arm to arrest the radial movement of the reduction unit. Also, ensure that the unit is axially free to allow free movement of the reduction unit.
5. Whenever possible, protect the reduction unit against solar radiation and bad weather.
6. Ensure the motor is adequately ventilated by assuring good passage of air from the fan side.
7. In the case of ambient temperatures $< -5^\circ\text{C}$ and $> +45^\circ\text{C}$, contact Gaeyah.
8. Various accessories like pulleys, gear wheels, couplings, shafts, etc. must be mounted on the solid or hollow shafts using special holes or other systems to ensure correct operation without risking damage to the bearings or external parts of the unit.
9. Do not paint the rubber parts or on the breather as it may lead to leakage of oil from the gear unit.
10. Use proper tools to remove the oil seals.
11. At regular intervals, check the oil level inside the gear unit.
12. Suppose the gear unit is not coupled with the motor, please pay attention to the mounting position B5, B1, etc.
13. Check whether the tolerance between the shaft and motor flange fits for the essential standard.
14. Clean the dirt and the paint on the surfaces of the shaft, center bore, and the flange.
15. Mounting avoids the gear unit incur strength.
16. Check the position and the deviation of the motor key slot.
17. Lubricate the surfaces in mesh properly to avoid seizure or oxidation.
18. Starting must take place gradually, without immediately applying the maximum load.
19. Ensure equipment close to the unit doesn't damage the motor or gear unit by spillage of oil, water, etc. Care to be taken while fitting.

GAEYAH RANGE OF PRODUCTS INCLUDE:

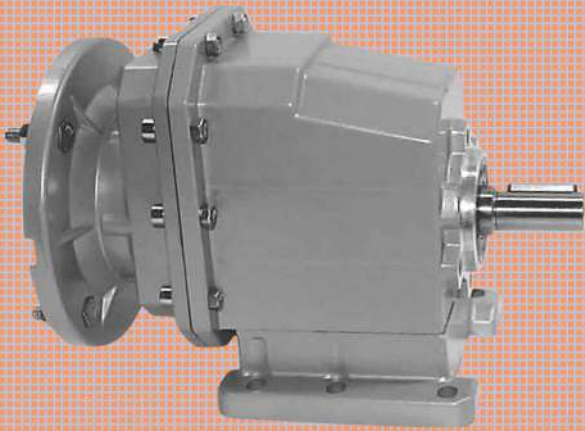

**GHP Series Helical
Geared Motor
Upto Size 35**

**GPM Series Hypoid
Geared Motor
Upto Size 90**

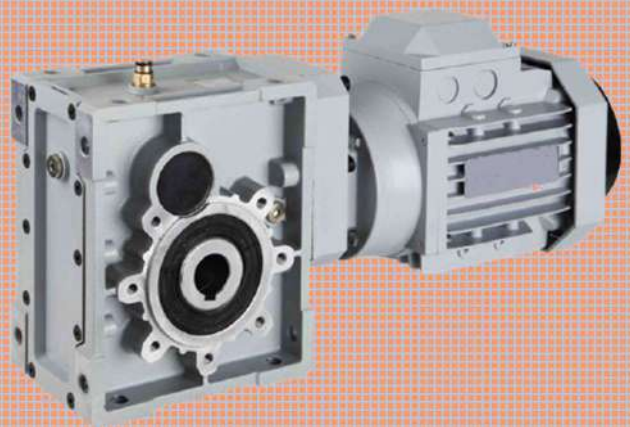

**GEM Series Electric
Motor
Upto Size 5.5kW**



No. 17/3B, G J Complex,
Avadi Main Road, Seneerkuppam,
Chennai 600056, India.

sales@gaeyah.com
91 8754422004
www.gaeyah.com

**GAEYAH Registered Trade Mark of Gaeyah Corporation*